

# University of Pennsylvania Shipping Manual for Infectious Substances, Biological Materials, And DRY ICE

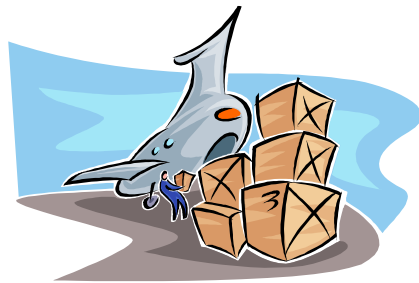

January 2019

University of Pennsylvania  
Environmental Health & Radiation Safety

Phone: 215-898-4453  
FAX: 215-898-0140  
WEB: [www.ehrs.upenn.edu](http://www.ehrs.upenn.edu)

## Table of Contents

	Page
<b>Part I Introduction</b> .....	<b>1</b>
<b>A.</b> Purpose of shipping regulations .....	<b>1</b>
<b>B.</b> What are "Dangerous Goods" and who regulates them? .....	<b>2</b>
<b>C.</b> Classes of "Dangerous Goods" .....	<b>3</b>
<b>D.</b> Mandatory training for shippers of all "Dangerous Goods" .....	<b>5</b>
<b>Part II How to Ship</b> .....	<b>7</b>
<b>A.</b> Classification (What are you shipping?) .....	<b>8</b>
a. Infectious substances, category A	
b. Biological substances, category B	
c. Genetically Modified Micro-Organisms (GMMOs) and Genetically Modified Organisms (GMOs)	
d. Exempt Patient Specimens	
e. Research Material, non-infectious	
f. Excepted Quantities (Shipping Dangerous Goods as Preservatives from Classes 3, 8 and 9)	
i. Formalin .....	<b>11</b>
g. deminimis exception	
h. Infected Animals	
<b>B.</b> UN Identification Number and Proper Shipping Name .....	<b>14</b>
a. Infectious substances, category A	
b. Biological substances, category B	
c. Dry Ice	
d. Genetically Modified Organisms (GMOs)	
<b>C.</b> Packaging .....	<b>15</b>
1. Infectious substances, category A	
2. Biological substances, category B,	
3. Genetically Modified Organisms (GMOs)	
4. Exempt Patient Specimens	
5. Research Material, Non-Infectious	
6. Dry Ice or Carbon Dioxide, solid	
7. Liquid Nitrogen	
8. Dry Shipper	
9. Overpacks	
<b>D.</b> Marking and Labeling .....	<b>20</b>
1. Infectious substances, category A, PI 620	
2. Biological substances, category B, PI 650	
3. Genetically Modified Organisms (GMOs)	
4. Exempt Patient Specimens	
5. Dry Ice or Carbon Dioxide, solid	
6. Example marked boxes.....	<b>23 - 33</b>
7. Flow chart.....	<b>34</b>
<b>E.</b> Documentation .....	<b>35</b>
1. Shipper's Declaration for Dangerous Goods	
2. Air Waybill	

<b>Part III</b>	<b>Special Regulations</b> .....	<b>39</b>
<b>A.</b>	Select Agents .....	<b>40</b>
<b>B.</b>	Import and Export of Biological Materials and Infectious Substances .....	<b>41</b>
1.	Import and Export Permits	
2.	Export Control Laws	
3.	Commercial Invoice	
<b>Part IV</b>	<b>Shipping Company Restrictions</b> .....	<b>45</b>
<b>Part V</b>	<b>Emergency Response</b> .....	<b>47</b>
<b>Part VI</b>	<b>Summary</b> .....	<b>48</b>
<b>Tables</b>		
Table 1	(The Category A List) .....	<b>49-50</b>
Table 2	(Comparison of PI 620 and PI 650) .....	<b>51</b>
Table 3	(Summary of Shipping Information) .....	<b>52</b>
Table 4	(Select Agents & Toxins List) .....	<b>53</b>
<b>Appendices</b>		
Appendix A	(Manufacturers of Certified Shipping Containers) .....	<b>55</b>
Appendix B	(UN Specifications and Performance Tests) .....	<b>56</b>
Appendix C	(Diagram triple packaging and labeling) .....	<b>57-58</b>
Appendix D	(Shippers Declaration for Dangerous Goods Form) .....	<b>59</b>
Appendix E	(Export controls on biological and chemical materials) .....	<b>60</b>
Appendix F	(Certification Statement template letter) .....	<b>61</b>

# Part I. Introduction

## A. Purpose of shipping regulations

Shipping regulations have been published by international and national regulators in order to provide procedures for the shipper by which articles and substances with hazardous properties can be safely transported by air or ground.

“Infectious substances are transported for a variety of different reasons, within countries and across international borders. It is incumbent upon shippers to ensure packaging and shipping conditions meet regulatory requirements to preserve the integrity of materials, and facilitate their timely arrival at destination.” (*World Health Organization; Guidance on Regulations for the Transport of Infectious Substances.*)

## B. What are “Dangerous Goods” and who regulates them?

**Dangerous Goods** are defined as “articles or substances which are capable of posing a significant risk to health, safety, property or the environment when transported by surface or air”.

The recommendations for the transport of **Dangerous Goods** were first initiated to facilitate transport of those goods while ensuring the safety of people, property and the environment.

The United Nations publishes recommendations for packing and shipping **Dangerous Goods**. Although the International Civil Aviation Organization (**ICAO**) writes the technical instructions for the *Safe Transport of Dangerous Goods by Air*, the international community follows the **IATA** regulations.

The International Air Transport Association (**IATA**) is composed of the world’s major airlines. They write the “IATA Dangerous Goods Regulations” which are based on the ICAO Technical Instructions. The IATA Dangerous Goods Regulations designate the **shipper** as having the responsibility for making sure all packaging is done properly.

The Department of Transportation (**DOT**) regulates the transport of “Hazardous Materials” in the United States. The Federal Regulations (49 CFR) also defer to the Technical Instructions from ICAO. DOT uses the term “Hazardous Materials” instead of “Dangerous Goods”. Hazardous Materials are defined as a substance or material the Secretary of Transportation has determined as capable of posing an unreasonable risk to health, safety, and property when transported by commerce.

### Structure Of Governmental Bodies

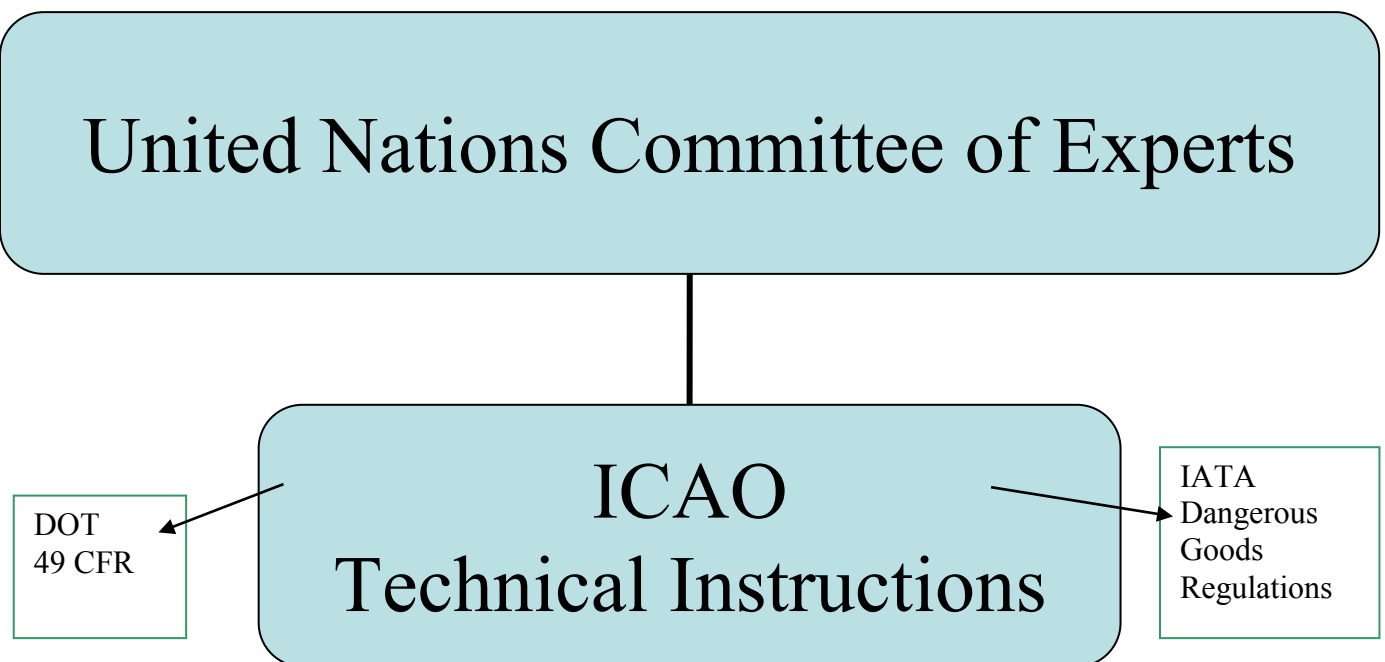

Some other agencies that may be involved with regulating packing and shipping are:

- Occupational Safety and Health Administration (OSHA)
- US Public Health Service (PHS)
- United States Postal Service (USPS)

## C. Classes of Dangerous Goods

- Dangerous goods are defined as those goods that meet the criteria of one or more of nine United Nations (UN) hazard classes. There are nine classes that relate to the type of hazard.

### Class 1 - Explosives



### Class 2 - Gases



### Class 3 - Flammable liquids



### Class 4 - Flammable solids



### Class 5 - Oxidizing Substances and Organic Peroxides



### Class 6 - Toxic and Infectious Substances



### Class 7 - Radioactive Material



### Class 8 - Corrosives



### Class 9 - Miscellaneous Dangerous Goods



- The scope of this document is to provide guidance in transporting those Dangerous Goods that fall under Class 6 (specifically Infectious Substances, division 6.2) and Class 9 (specifically dry ice and genetically modified organisms).

**Class 6, Division 6.2 (Infectious Substances)**



**Class 9, Miscellaneous  
(genetically modified organisms and dry ice)**



**This manual will discuss classification, shipping, packaging, and documentation regulations for sending the following items by ground or by air:**

- Infectious substances (human and animal pathogens)
- Biological substances (human and animal pathogens)
- Genetically-modified materials
- Patient specimens (clinical human and animal)
- Research materials
- Biological products
- Dry Ice

## **D. Training is *mandatory* for anyone involved with the shipping of "Dangerous Goods".**

A "shipper" is defined as someone that does any of the following jobs:

- Marking and labeling packages
- Filling packages
- Accepting packages for shipment
- Supervising these activities
- Preparing shipping documentation
- Loading trucks

Training is an essential element in maintaining a safe regulatory regime. It is necessary for all individuals involved in the preparation or transport of dangerous goods to be properly trained to carry out these responsibilities prior to shipping.

Also, if you are a shipper, the carrier relies on your ability to properly package, label and declare goods.

It is the responsibility of the shipper to receive training on the proper packaging, documentation and shipping requirements in order to comply with the International Air Transport Association (**IATA**) and the Federal Department of Transportation (**DOT**). IATA requires training every two years for shipments by air and DOT requires training every three years.

**The University of Pennsylvania's training requirements follow the IATA regulations for training. Therefore, shipping training must be updated every TWO YEARS and when there are significant changes made. Always check the EHR website in January of each year for changes to the IATA regulations.**

Non-compliance to these regulations can result in significant penalties and fines:

- **Civil penalty not less than \$250**
- **Up to \$25,000 fine and up to 5 year jail sentence for individuals willfully violating the regulations**
- **Up to \$500,000 fine per incident for organizations**





**Everyone intending to ship biological materials and/or dry ice must complete the appropriate training. Please go to EHRIS website for specific instructions for the training program.**

**<http://www.ehrs.upenn.edu/programs/bio/transporting/>**

Once you have completed the shipping training, you will receive a "Shipping Certification Document" from EHRIS. **Keep these certificates in your personnel file.**

If you will be shipping human source materials, you must **also** complete the **OSHA Bloodborne Pathogens Training**. This is offered online through KnowledgeLink.

## Part II. How to Ship

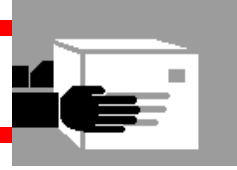

Preparing the package properly for shipping is *extremely* important!! Use the following steps to help you get ready to ship!

**A. Classification**

**B. UN Identification number and Proper Shipping Name**

**C. Packaging**

**D. Marking and labeling**

**E. Documentation**

## A. Classification (What are you shipping?)

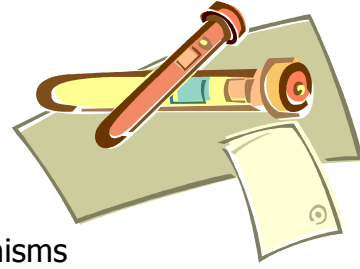

1. Regulated biological materials:
  - a. Infectious substances, category A
  - b. Biological substances, category B
  - c. Genetically modified organisms or microorganisms
2. Non-regulated biological materials
  - a. Exempt patient specimens (clinical human or animal samples)
  - b. Research Material, non-infectious
  - c. Other Non-regulated biological material
3. Chemicals in small quantities
  - a. Excepted Quantities
  - b. De Minimis Quantities
4. Infected or uninfected Live animals

### 1. Regulated biological materials: Class 6.2 Infectious Substances

**Infectious Substances** are materials which are known or are reasonably expected to contain an animal or human pathogen. Pathogens are defined as microorganisms (including bacteria, viruses, rickettsiae, parasites, fungi) and other agents such as prions or recombinant microorganisms, which can cause disease in humans or animals.

**Infectious Substances are divided into sub-two categories, Category A and Category B.** These categories are based on a detailed, case-by-case, risk assessment of microorganisms known to be pathogens (**see Table 1**). The categorization is the result of the consideration of scientific data concerning the **risks of transmission and infection posed during transport** of each species of microorganism.

#### a. Infectious substance, category A

An infectious substance which is transported in a form that, when exposure to it occurs, is capable of causing permanent disability, life-threatening or fatal disease in otherwise healthy humans or animals. An exposure occurs when an infectious substance is released outside of the protective packaging, resulting in physical contact with humans or animals. Substances that meet this criteria can be found in the Category A List found in **Table 1**.

#### b. Biological substances, category B

An infectious substance that does not meet the criteria for inclusion in Category A. These are referred to as *Biological Substances*. These substances are or contain human or animal pathogens not included in the Category A List.

### **c. Genetically modified organisms or Genetically modified microorganisms**

Genetically modified organisms (GMO) or microorganisms (GMMO) are genetically modified **organisms** or **microorganisms** in which genetic material has been purposely altered through genetic engineering in a way that does not occur naturally.

If GMOs or GMMOs do NOT meet the definition of a toxic or infectious substance, they must be assigned to the category of Genetically Modified Organisms or Genetically Modified Microorganisms, UN3245. GMOs or GMMOs do NOT need to be classified as such when shipped within the United States.

*Genetically modified live animals must be transported under terms and conditions of the appropriate national authorities of the States of origin and destination.*

## **2. Non-regulated biological materials**

### **a. Exempt Patient Specimens (human and animal)**

**Patient specimens** are materials, collected directly from humans or animals, including, but not limited to, excreta, secretions, blood and its components, tissue and tissue fluid swabs, and body parts being transported for purposes such as research, diagnosis, investigational activities, disease treatment and prevention.

If patient specimens are not expected to be infectious, they are exempt; however, they must meet a minimum packing requirement which is basic triple packaging. Shipments must also be labeled "Exempt human specimen" or "Exempt animal specimen".

#### **NOTE**

*In determining whether a patient specimen has a minimal likelihood that pathogens are present, an element of professional judgment is required to determine if a substance is exempt under this paragraph. That judgment should be based on the known medical history, symptoms and individual circumstances of the source, human or animal, and endemic local conditions. Examples of specimens which may be transported under this paragraph include the blood or urine tests to monitor cholesterol levels, blood glucose levels, hormone levels, or prostate specific antigens (PSA); tests required to monitor organ function such as heart, liver or kidney function for humans or animals with non-infectious diseases, or therapeutic drug monitoring; tests conducted for insurance or employment purposes and are intended to determine the presence of drugs or alcohol; pregnancy tests; biopsies to detect cancer; and antibody detection in humans or animals.*

- Patient specimens may fall under Infectious Substance, Category A if they are known or reasonably known to contain a pathogen from Table 1 or under Biological Substance, Category B if they are known or reasonably known to contain a human or animal pathogen not found on Table 1.

**b. Research Materials - not infectious (materials used only for research)**



There are particular biological materials that are exempt from the shipping regulations. Exempted materials are not excluded from triple packaging. They are exempted from DOT and IATA regulations.

- Non-infectious biological materials derived from humans, animals or plants. Examples include:
  - non-infectious cells (cell-lines) or tissue cultures
  - DNA, RNA, or other genetic elements
  - antibodies
  - plasmids (not infectious)
- Substances which do not contain infectious substances or substances which are unlikely to cause disease in humans or animals.
- Substances containing micro-organisms, which are non-pathogenic to humans or animals (i.e. Adeno-associated Virus, K-12 *E. coli* strains)
- Substances in a form that any present pathogens have been neutralized or inactivated such that they no longer pose a health risk.
- Environmental samples (including food and water samples), which are not considered to pose a significant risk of infection, are not subject to these regulations unless they meet the criteria for inclusion in another class.
- Dried blood spots.
- Fecal occult blood screening test.
- Blood or blood components which have been collected for the purpose of transfusion or the preparation of blood products to be used for transfusion or transplantation.
- Biological products including an experimental or investigational product or component of a product, subject to federal approval, permit, review or licensing requirements such as those required by the Food and Drug Administration or the USDA.
- Licensed vaccines
- Organs for transplant (transported by private courier)

### 3. Chemicals in small quantities

#### a. Excepted Quantities (Shipping Dangerous Goods as Preservative from Class 3, 8, or 9)

Shipping small quantities of chemicals used as preservatives from Classes 3, 8 or 9 can be shipped under the limitation of Excepted Quantities. These chemical preservatives can be used in shipments of Infectious substance, category A or Biological substance, category B, or shipping non-regulated materials.

<b>Class 3</b>		Flammables	<u>Examples of Class 3 Preservatives:</u> Ethanol Ethanol solution Formaldehyde solution (>10%) Formalin (>10%) Alcohols, n.o.s. Isopropanol Isopropyl Alcohol
<b>Class 8</b>		Corrosives	
<b>Class 9</b>		Miscellaneous (Not including GMOs)	



#### **Formalin**

*Formalin is a mixture of formaldehyde and methyl alcohol. IATA identifies formalin as, Formaldehyde solution:*

- *Full strength formalin is 37% formaldehyde  
Formalin or Formaldehyde solution with >25% Formaldehyde is classified as “**Formaldehyde solution, flammable, UN1198,3 (8), PGIII.**”  
Must be shipped as a Dangerous Good with Shippers Declaration!*
- *Formalin or formaldehyde solution with >10% but <25% formaldehyde is classified as “**UN3334, Aviation regulated liquid, n.o.s. (formaldehyde), 9**” for transportation by air. IF shipped by highway it does not require classification as a hazardous material. Follow instructions below.*
- *Formaldehyde solution with < 10% formaldehyde is NOT REGULATED for transport by highway or air.*

If the volume of preservative for the **primary container** exceed **30ml** and/or the **total amount exceeds 500ml**, please contact EHRS to help ship. These amounts fall out of the “excepted and “exempt” amounts.

**b. de minimis exception**

Hazardous materials subject to the de minimis exception are limited to Packing Group II and III of the following Hazard Classes and Divisions:

- o Class 3 – Flammable and Combustible Liquids
- o Division 4.1 – Flammable Solids
- o Division 4.2 – Spontaneously Combustible
- o Division 4.3 – Dangerous When Wet
- o Division 5.1 – Organic Peroxide
- o Class 8 – Corrosive Material
- o Class 9 – Miscellaneous

The maximum quantity per inner receptacle or article is limited to one (1) mL for liquids **or...** one (1) g for solids

The maximum quantity per outer packaging does not exceed one hundred (100) mL for liquids or one hundred (100) g for solids

**4. Infected or Uninfected Live Animals**

The shipment of infected animals must not be transported by air unless specific regulations are met. The shipment of any live animals must meet AAALAC standards and IATA's Live Animal Regulations. Contact ULAR with any questions concerning the transport of live animals. Also, any animals transported to other states must be done under the terms and conditions approved by APHIS and USDA.



**Make sure that you correctly classify the material to be shipped. Packaging, marking and documentation will depend on proper classification!**



## B. UN Identification Number and Proper Shipping Name

Dangerous goods are assigned to UN numbers and proper shipping names according to their hazard classification and their composition.

Specific wording is used for the terms Infectious Substance, category A; Biological Substance, category B; and Carbon Dioxide, solid or "Dry Ice".

### 1. Infectious substance, category A is assigned either UN 2814 or UN 2900:

UN 2814 is used for infectious substances that are considered human pathogens only or pathogens that infect humans and animals.

The proper shipping name for UN 2814 must be written as:

***"Infectious substance, affecting humans (name of pathogen)".***

- *Example:* Infectious substance, affecting humans (Hepatitis B virus).

UN 2900 is used for infectious substances that are considered pathogens for animals only.

The proper shipping name for UN 2900 must be written as:

***"Infectious substance, affecting animals (name of pathogen)".***

- *Example:* Infectious substance, affecting animals (Vesicular stomatitis virus).

### 2. Biological substance, Category B is assigned UN 3373:

The proper shipping name for UN 3373 must be written as:

***"Biological substance, category B".***

### 3. Dry Ice or Carbon Dioxide, solid is assigned UN 1845.

The proper shipping name for UN 1845 must be written as:

***"Dry Ice" or "Carbon dioxide, solid".***

### 4. Genetically Modified Organisms (GMO) are assigned UN 3245.

The proper shipping name for GMO's must be written as:

***"Genetically modified organisms" or "Genetically modified microorganisms".***

**\* other classifications of biological material, such as exempt patient specimen or research material, are not proper names and, therefore, do not have a UN number**

## C. Packaging

### Follow the Packaging Instructions (PI)

All potentially hazardous biological materials must be packaged to withstand leakage of contents, shocks, temperature, pressure changes and other conditions that can occur during ordinary handling in transportation. **Please refer to Appendix A for vendors that supply certified packaging for biological materials.** When ordering, specify what category of material you will be shipping: *Infectious substances, category A or Biological substances, category B, Dry Ice, etc.* Different categories have slightly different packaging requirements as specified in the IATA Packaging Instructions, but all follow the basic **triple packaging requirements** (Appendix C).



#### 1. Infectious Substances, Category A:

IATA Packaging Instruction (PI) 620 must be used for Category A packages. These requirements ensure that packages will arrive at their destination in good condition and present no hazard to persons or animals during transport.

### PI 620

- Triple packaging (see Appendix C)
    - Primary receptacle\*
      - Must be leakproof
      - Must be labeled with the name of the contents.
    - Secondary container\*
      - Must be leakproof
      - Must meet *UN performance standards for PI 650* (Table 2)
      - Must withstand an internal pressure of 95kPa
      - Absorbent material must be included in sufficient quantity to absorb the entire contents of all primary receptacles. This is placed between the primary receptacle and the secondary packaging.
      - If multiple fragile primary receptacles are placed in a single secondary packaging, they shall be either individually wrapped or separated so as to prevent contact between them.
    - Rigid outer container
      - Must be certified with a *UN specification mark*. This will be marked on the box. (Appendix B)
      - An itemized list of contents must be enclosed between the secondary and outer container.
      - The maximum quantity of infectious material that can be shipped by air in one package is 4L or 4kg.
        - \* The maximum quantity of infectious material that can be shipped via passenger aircraft is 50mL or 50g.
- *When shipping infectious substances, you are required to use one manufacturer's packaging system. Using one manufacturer's secondary container in different manufacturer's outer box can be dangerous and is illegal since it may not meet the required performance standard for the packaging.*

## 2. Biological substance, category B

IATA Packaging Instruction (PI) 650 must be used for Category B packages. These requirements ensure that packages will arrive at their destination in good condition and present no hazard to persons or animals during transport.

### PI 650

- Triple packaging (see Appendix C for graphic)
  - Primary receptacle\*
    - Must be leak proof
    - Packaging containing liquids, closures of primary containers are required to be held securely by secondary means, such as adhesive tape, or friction sleeves.
    - Must not contain more than 1L or 1kg
  - Secondary container
    - Must be leak proof
    - Must meet *UN performance standards for PI 650* (Table 2)
    - Must withstand an internal pressure of 95kPa
    - Absorbent material of sufficient quantity to absorb the entire contents of the primary receptacle.
  - Rigid outer container
    - Must not contain more an 4L or 4kg
    - Good quality, strong enough to withstand the shipping process
    - An itemized list of contents must be enclosed between the secondary and outer container.

\* Primary receptacles must be packed in secondary containers in such a way that, under normal conditions of transport, they cannot break, be punctured or leak their contents into the secondary packaging.

## 3. Genetically Modified Organisms or Microorganisms (GMOs or GMMOs)

### PI 959

- If the GMO or GMMO meets neither of the category A or category B criteria, it is classified as a GMO or GMMO UN3245 using the Packing Instruction 959.
- Primary receptacle and secondary packaging must be leak proof
- Absorbent must be placed between the primary receptacle and secondary packaging, of sufficient quantity to absorb the entire contents of the primary receptacle.
- Primary receptacle and secondary packaging must maintain integrity at various temperatures and pressures.
- Rigid outer container of good quality, strong enough to withstand the shipping process

## 4. Exempt Patient Specimens

**No Packaging Instructions! Use triple packaging.**

Patient specimens for which there is minimal or no likelihood that pathogens are present are not subject to IATA Regulations if the specimen is transported in a packaging which will prevent any leakage and which is marked with the words “Exempt human specimen” or “Exempt animal specimen”, as appropriate. The packaging must **triple packaged** to meet the following conditions:

A. The packaging must consist of three components:

1. a leakproof primary receptacle(s)
2. a leakproof secondary packaging
3. An outer packaging of adequate strength for its capacity, mass and intended use, and with at least one surface having minimum dimensions of 100mm x 100mm (4in X 4in).

B. For liquids, absorbent material in sufficient quantity to absorb the entire contents must be placed between the primary receptacle(s) and the secondary packaging so that, during transport, any release or leak of a liquid substance will not reach the outer packaging and will not compromise the integrity of the cushioning material.

C. Quantities allowed for passenger and cargo:

The primary receptacle must not exceed 500ml or 500g. The outer packaging must not contain greater than 4L or 4kg.

\* packages with quantities exceeding these limits should be shipped under Biological substances, category B

**5. Research Material, non-infectious (Biological Products, non-infectious biological materials)**

**No Packaging Instructions!  
Use triple packaging to prevent leaks!**

Although this materials is not subject to IATA Regulations, it should be packaged in such a way to prevent leaking. Triple packaging should **always** be used. (See Appendix C)

**6. Dry Ice**

**PI 954**

If shipping dry ice, outer packaging must allow for the release of carbon dioxide gas when the solid sublimates.

**Do NOT tape down the lid to the Styrofoam box!**

Dry ice must be placed outside the secondary packaging. Interior supports must be provided to secure the secondary container as the refrigerant sublimates.

**\* Styrofoam box is not approved UN specification packaging and is not allowed to be used at the outer shipping container \***

Dry ice is considered a miscellaneous hazard (Class 9) by IATA. Packages containing dry ice must bear a Class 9 label and be marked with the proper shipping name, UN number, and net quantity, (e.g., Dry Ice, UN 1845, 3 kg).

A Shippers Declaration for Dangerous Goods is not required for shipments in which dry ice is the only hazardous material. Always include dry ice on the Declaration for shipments that include other hazardous materials, such as infectious substances.

## 7. Excepted Quantities

- The primary receptacle must not exceed **30ml** and the outer package must not exceed **500 ml** preservative. Primary receptacle must not be completely filled at a temperature of 55°C (130°F) to allow for expansion.
- Primary receptacle must be made of plastic greater than 0.2mm thick
- Closures of primary receptacle must be held securely in place with tape, wire, or other positive means. Screw cap containers must be leakproof.
- Primary receptacle must be secured in intermediate packaging along with enough absorbent to absorb all of the liquid within the primary receptacle
- The intermediate packaging must be securely packed in a strong rigid outer packaging

## 8. De Minimis Quantities

Packaging for qualifying materials and quantities must be packed in sturdy packaging

- The primary receptacle must not exceed **1 ml** and the outer package must not exceed **100 ml** of liquid.
- Primary receptacle must be secured with cushioning material
- Outer packaging must be in a strong rigid container

## 8. Liquid Nitrogen

**PI 202 for open and closed cryogenic receptacles**

Specimens being shipped with liquid nitrogen are regulated and the liquid nitrogen is a dangerous good. This will need to be shipped as UN1977 Nitrogen, refrigerated liquid. **Please contact EHRS if you will be using liquid nitrogen!**

## 8. Dry Shipper

**Follow Special Provision A152**

**– "not restricted"**

Biological materials can be shipped refrigerated in dry shippers. These are insulated packages containing refrigerated liquid nitrogen fully absorbed in a porous filter within the shipper.



These shippers are not regulated in and of themselves but must be designated with the special provision A152.

## 9. Overpacks

An overpack can be used to combine several triple packages into one large package. This may be done to save freight charges when shipping multiple samples.

Each triple package inside the overpack must be properly marked and labeled. The outside of the overpack must bear the same markings and labels as the triple packages within including hazard labels, proper shipping names and net quantities.

The outer container of the overpack must also be marked with the word "Overpack". The overpack marking is an indication that packages contained within comply with prescribed specifications.

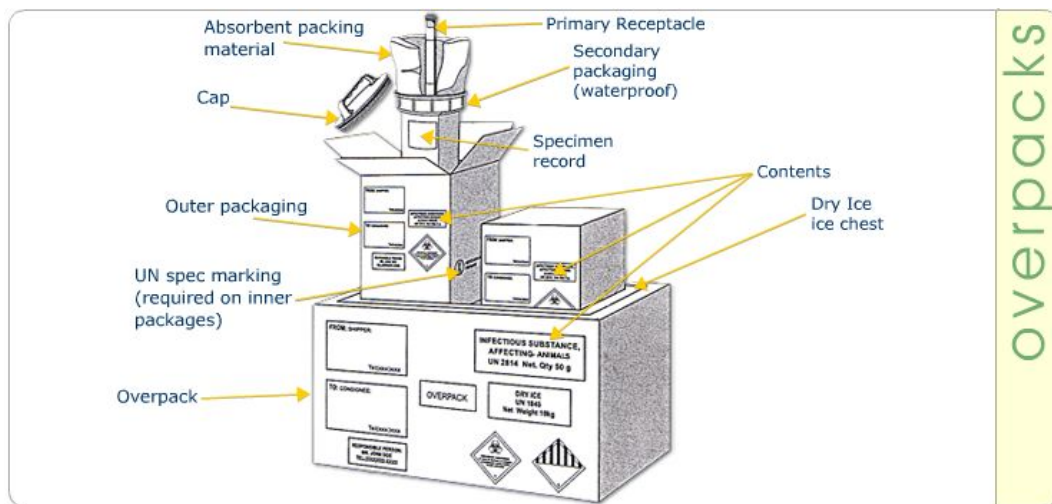

## D. Marking and Labeling

### 1. Infectious substances, category A, PI 620

The outer container must display the following information:

- Sender (shipper) and recipient's (consignee) full name, address and telephone number
- Name and phone number of responsible person (may be shipper, consignee, or third party knowledgeable about the shipment)
- "This End Up" or up arrows marked on two opposite sides
- UN certification seal (printed on box by vendor)
- Class 9 label (Fig. 2), UN 1845, proper name "Dry Ice", and weight of dry ice in kg (if packaged with dry ice)
- Infectious Substance, Class 6.2 label (Fig. 3)
- Proper shipping name "Infectious substance, category A"
- UN number and net quantity of infectious substance, min 6mm font \*,\*\*
- Cargo aircraft label if shipping over 50mL or 50g, min 120mm x 110mm edge to edge (Fig. 4)
- Labels must be of "durable quality"



Fig. 2



Fig. 3



Fig. 4

\*Shippers of Category A infectious substances shall omit the technical name from the proper shipping name marking on the outside of the package (Infectious substance, affecting humans is the proper shipping name, Ebola virus is the technical name). **Example: "Infectious substance, affecting humans"**

\*\*When the infectious substances to be transported are unknown but suspected of meeting the criteria for inclusion in Category A, they must be assigned to UN 2814 or UN 2900. The words "Suspected Category A Infectious Substance" must be shown in parentheses following the proper shipping name on the itemized list of contents inside the outer packaging and on the Shipper's Declaration for Dangerous Goods, but **not** on the outer packaging. **Example: Infectious substance affecting humans, (Suspected Category A Infectious substance)**

### 2. Biological substances, category B, PI 650

The outer container must display the following information:

- Sender (shipper) and recipient's (consignee) full name, address and telephone number
- Name and phone number of responsible person (may be shipper, consignee, or third party knowledgeable about the shipment) may be provided on the air waybill or on the package
- Proper name "Biological substances, category B", min 6mm font
- UN 3373 diamond, 2 mm thick boarder, min 6mm font, min 50mm point to point (Fig. 5)
- Class 9 label (Fig. 2), UN 1845, proper name "Dry Ice", and weight of dry ice in kg (if packaged with dry ice) (Fig. 6)
- Labels must be of "durable quality"





**Fig. 5**



**Fig. 6**

- Net quantity of agent is not required on outside of Category B packages.

### 3. Genetically Modified Organisms or Microorganisms, PI 959

The outer container must display the following information:

- Sender (shipper) and recipient's (consignee) full name and address
- UN 3245 diamond, 2 mm thick boarder, min 6mm font, min 50mm point to point (Fig. 7)
- Labels must be of "**durable quality**"

- Proper name is not required to be printed on the outside of the package



**Fig. 7**

### 4. Exempt Patient Specimens

The outer container must display the following information:

"Exempt human specimen" or "Exempt animal specimen", as appropriate.

### 5. Dry Ice or Carbon Dioxide, solid, PI 954

The outer container must display the following information:

- Class 9 label (Fig. 8), UN 1845, proper name "Dry Ice", and weight of dry ice in kg
- Labels must be in the form of a square set at an angle of 45° (diamond shape)
- Minimum dimensions must be 100 x 100 mm point to point
- The line inside the edge must be parallel and 5mm from the outside of that line to the edge of the label.
- Labels must be of "**durable quality**"
- "This End Up" or up arrows marked on two opposite sides



**Fig. 8**

DRY ICE  
UN 1845  
\_\_\_ KG net wt

Font type for "DRY ICE"

- > 30 kg – 12 mm type
- 5-30 kg Dry Ice – 6 mm type
- < 5 kg – adequate size



## 6. Excepted Quantity

1. If shipping with an Infectious substance, category A or Biological substance, category B, **there are no further labeling requirements for Excepted Quantity.**
2. If not shipping Infectious substance, category A or Biological substance, category B, **must use the designated label below:**

### Excepted Quantity label:

Label must be a minimum of 100mm on each side.

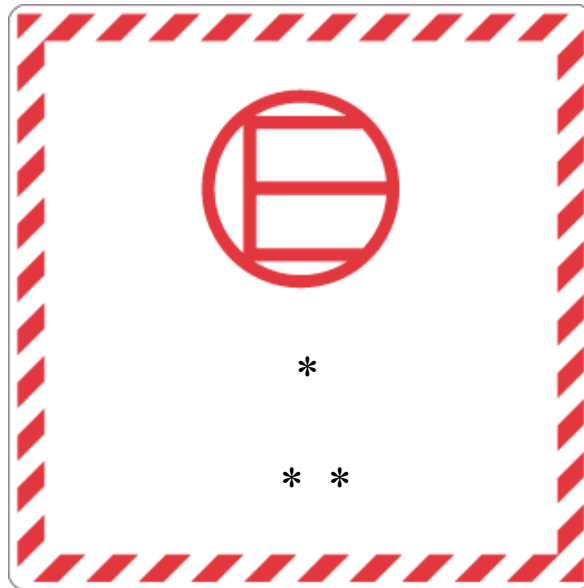

\* Mark this area with the class or, when assigned, the division number(s). For example, if using alcohol, class 3 would be indicated by writing 3 in place of \*.

\*\* If the name of the shipper or consignee is not shown elsewhere on the package, place it here in place of \*\*.

# Examples of Markings on Shipping Boxes

## Outer Box for Infectious Substance, affecting humans without Dry Ice

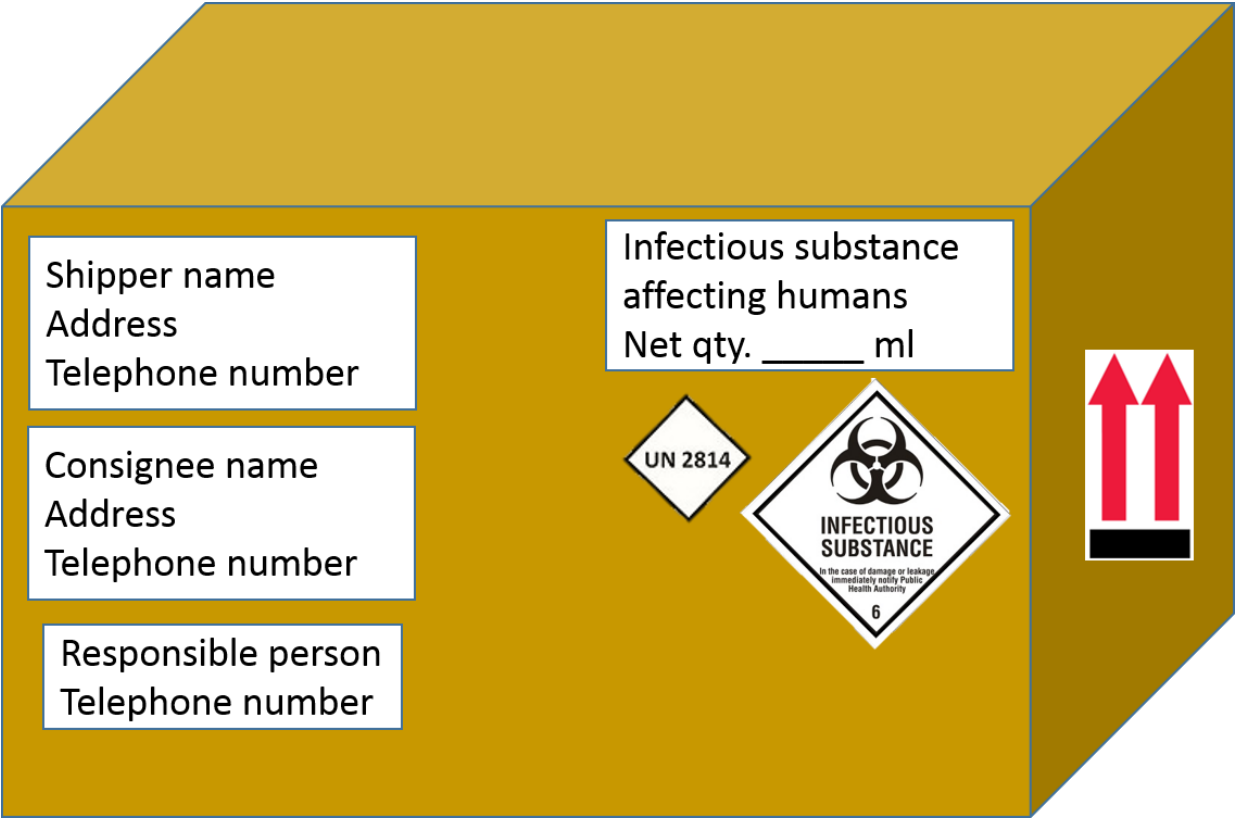

### Outer Box for Infectious Substance. Affecting humans with Dry Ice

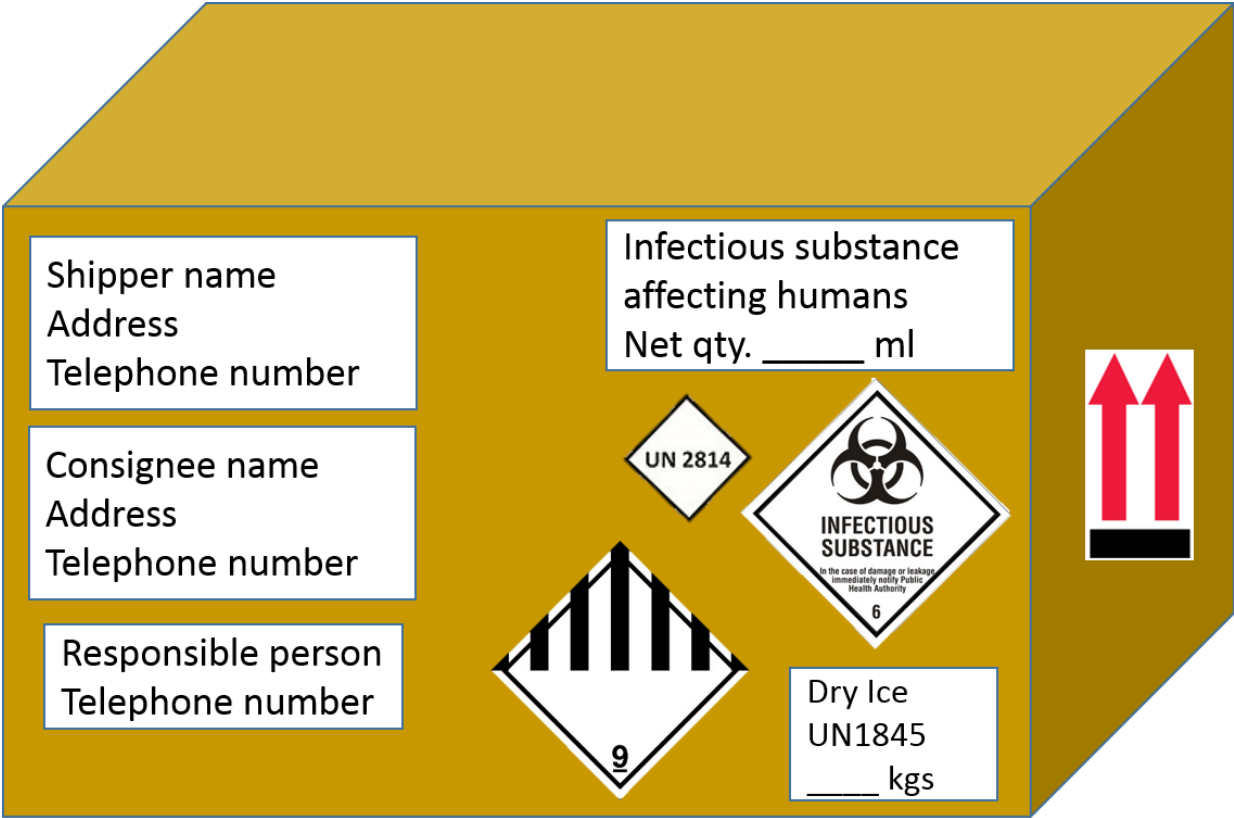

### Infectious Substance, affecting humans In an Overpack

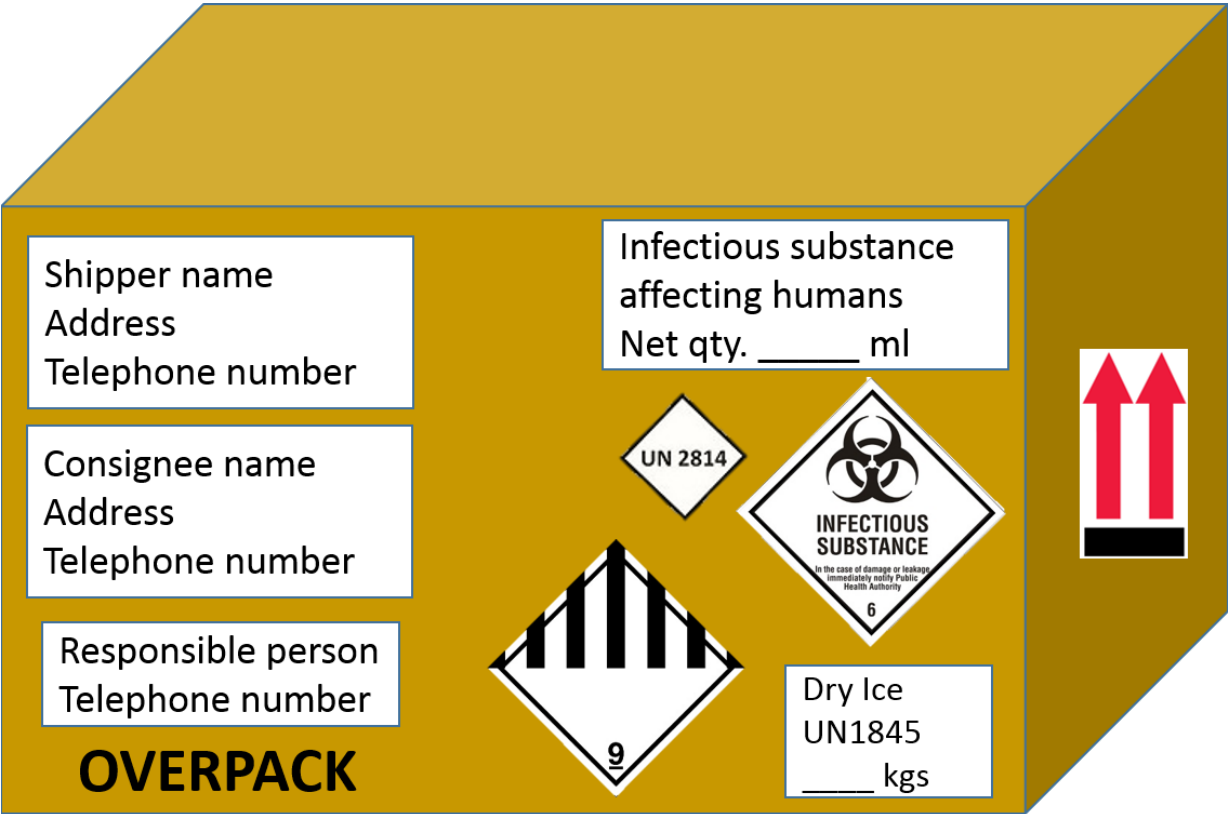

**Outer Box for “Biological substances, category B”  
without Dry Ice**

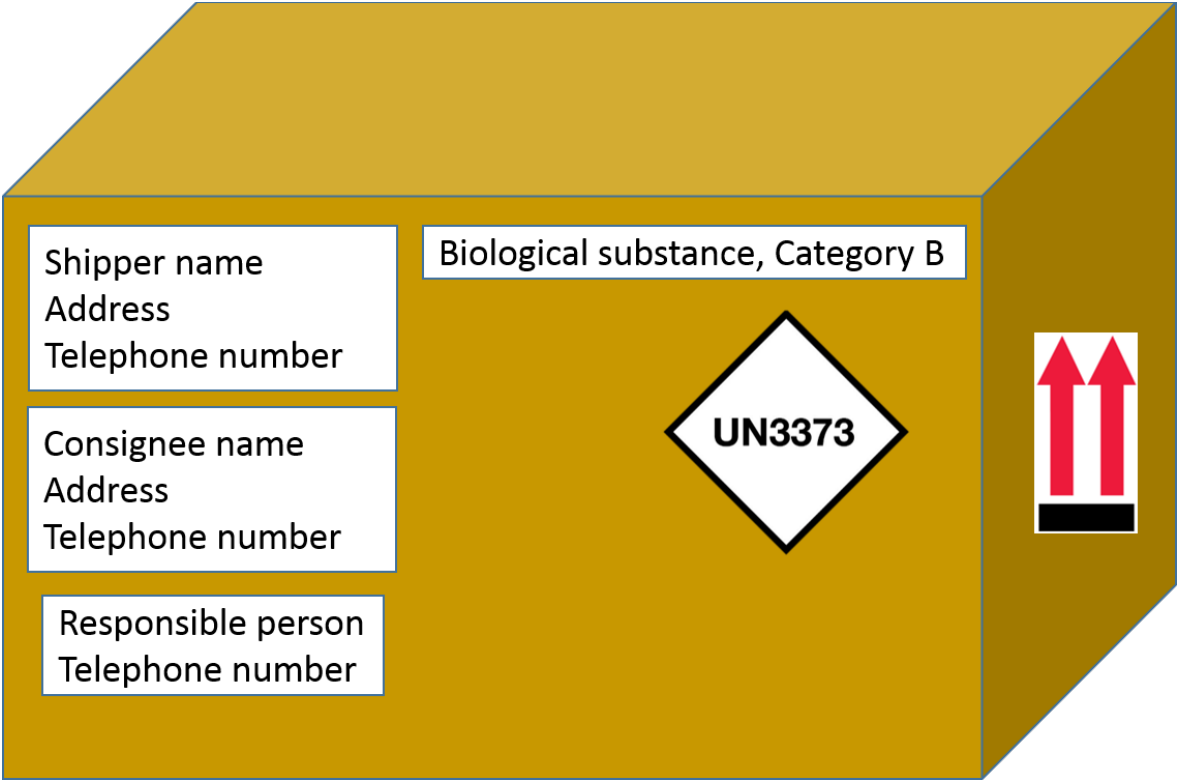

# Outer Box for "Biological substances, category B" with Dry Ice

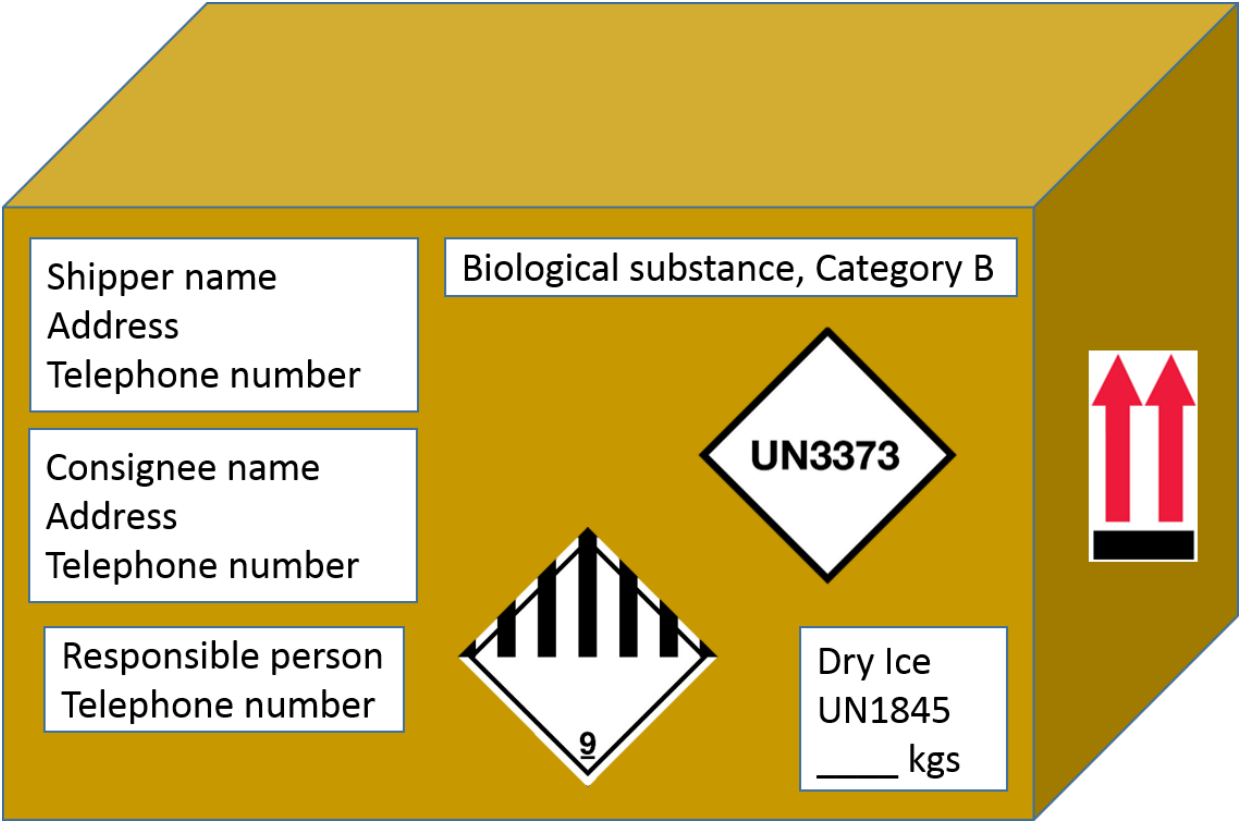

**Outer Box for Genetically Modified Organism  
without Dry Ice**

(for International, non-Cat A or Cat B shipments ONLY!)

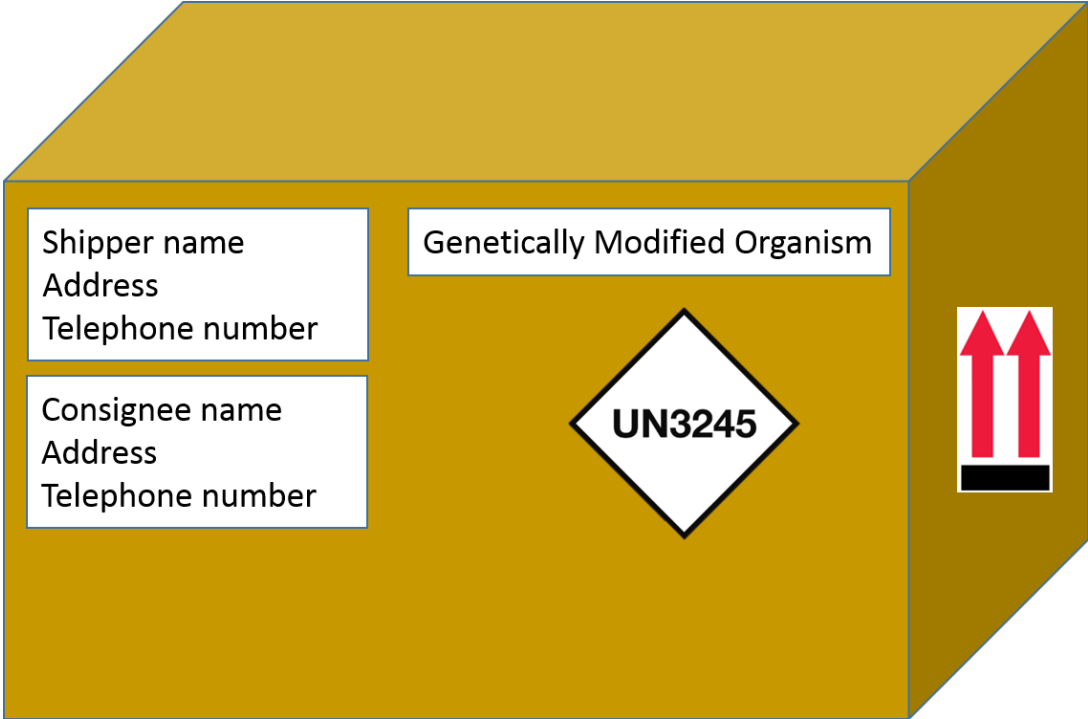

**Outer Box for Genetically Modified Organism  
with Dry Ice**  
(for International, non-Cat A or Cat B shipments ONLY!)

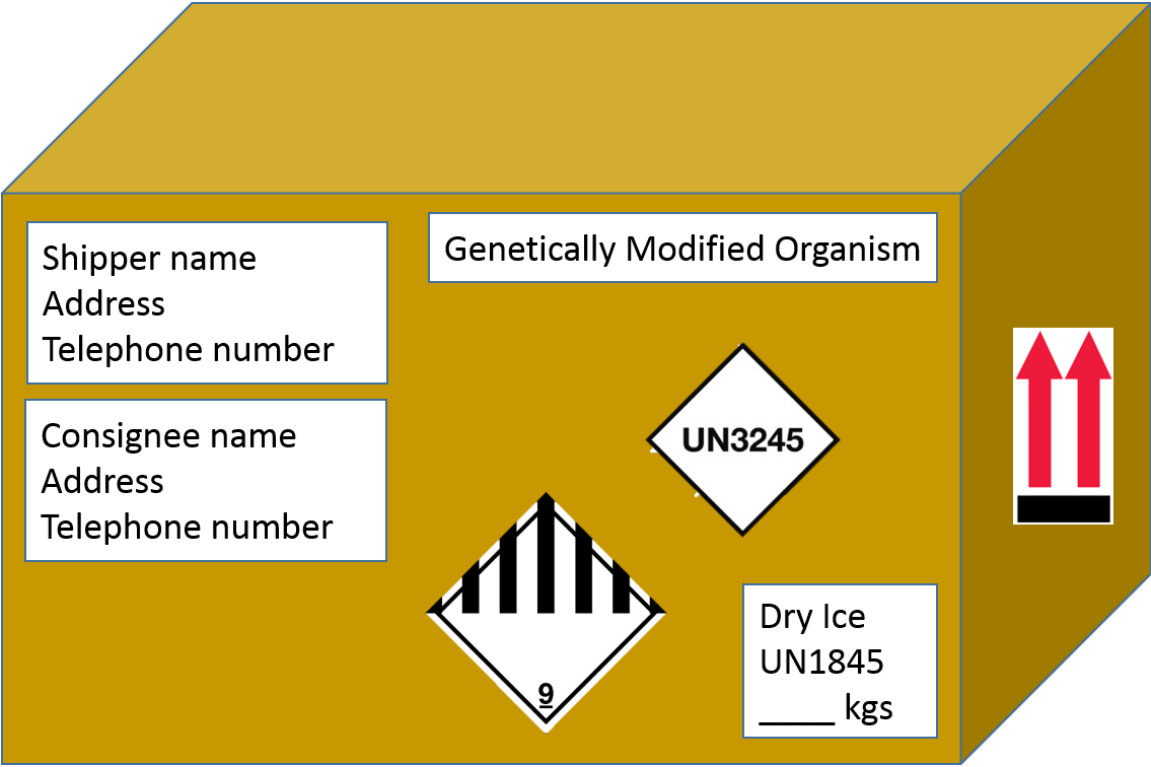



**Outer Box for Exempt Patient Specimens  
without Dry Ice**

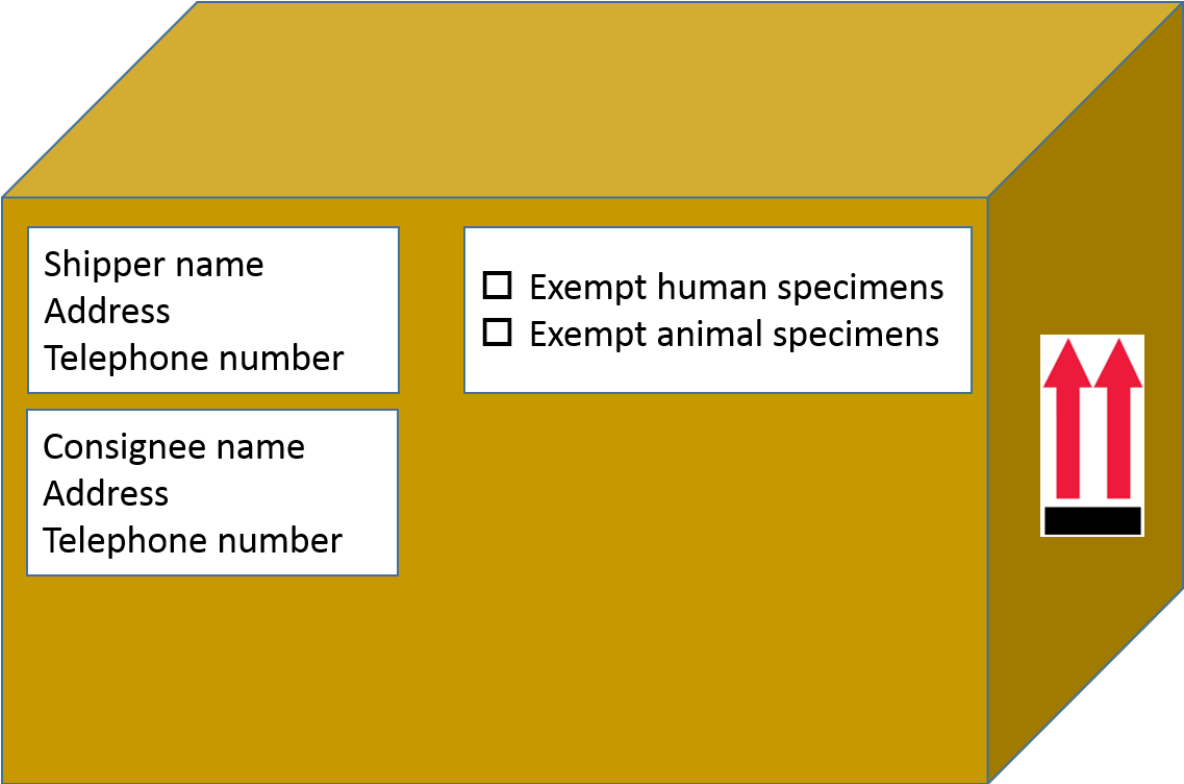

### Outer Box for Exempt Patient Specimens with Dry Ice

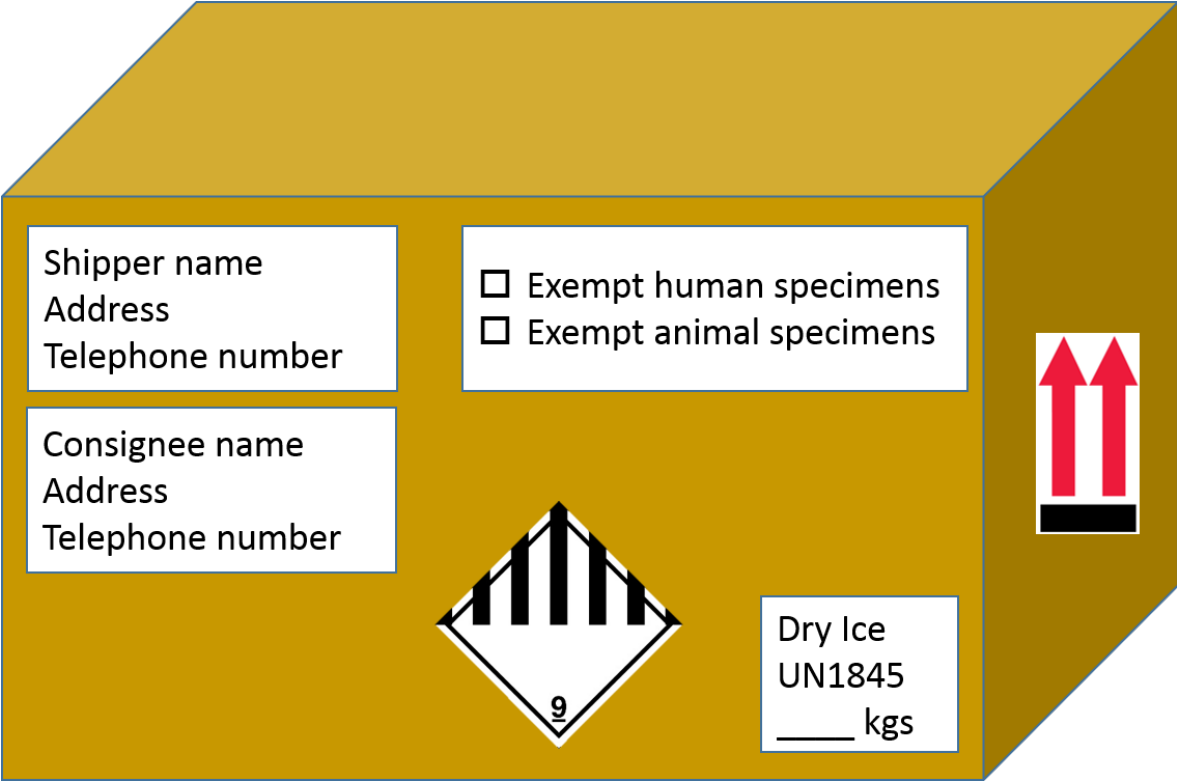

**Outer Box for Research Material, not infectious  
without Dry Ice**

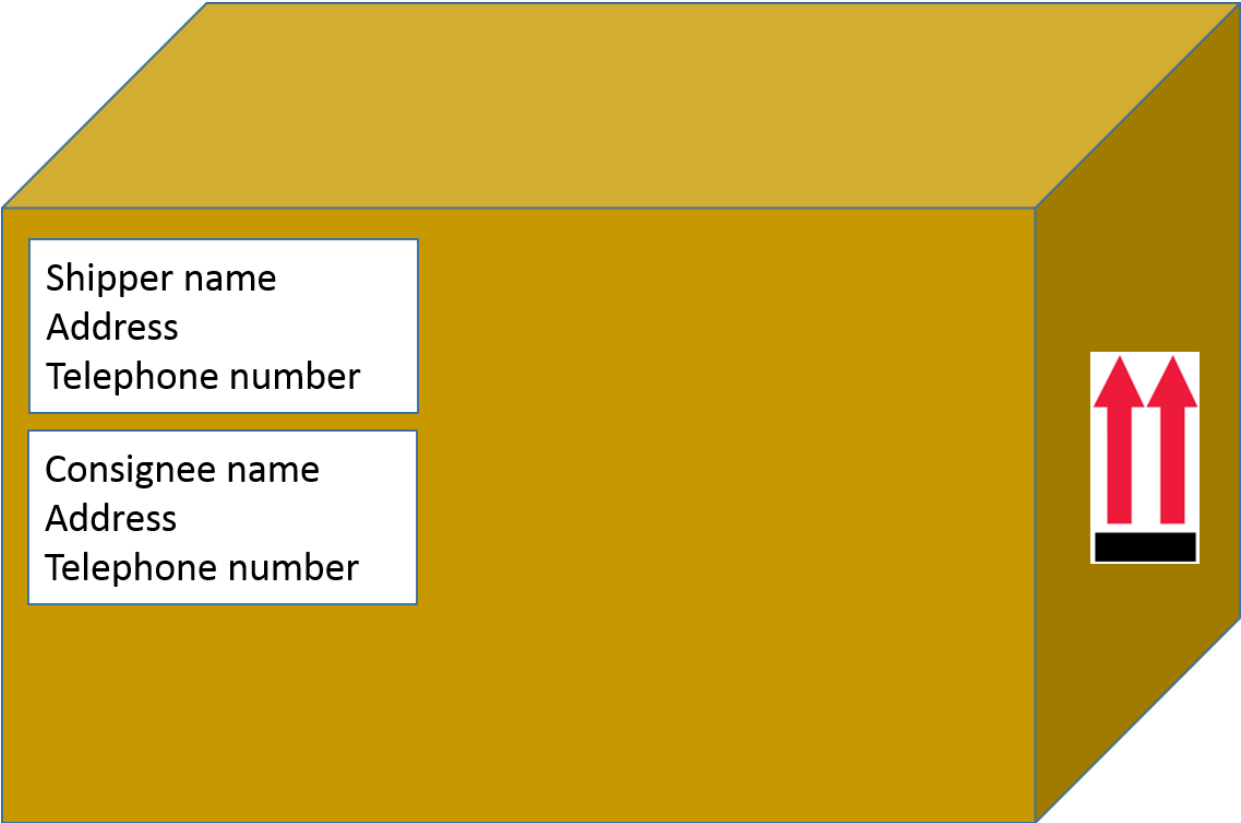

**Outer Box for Research Material, not infectious  
with Dry Ice**

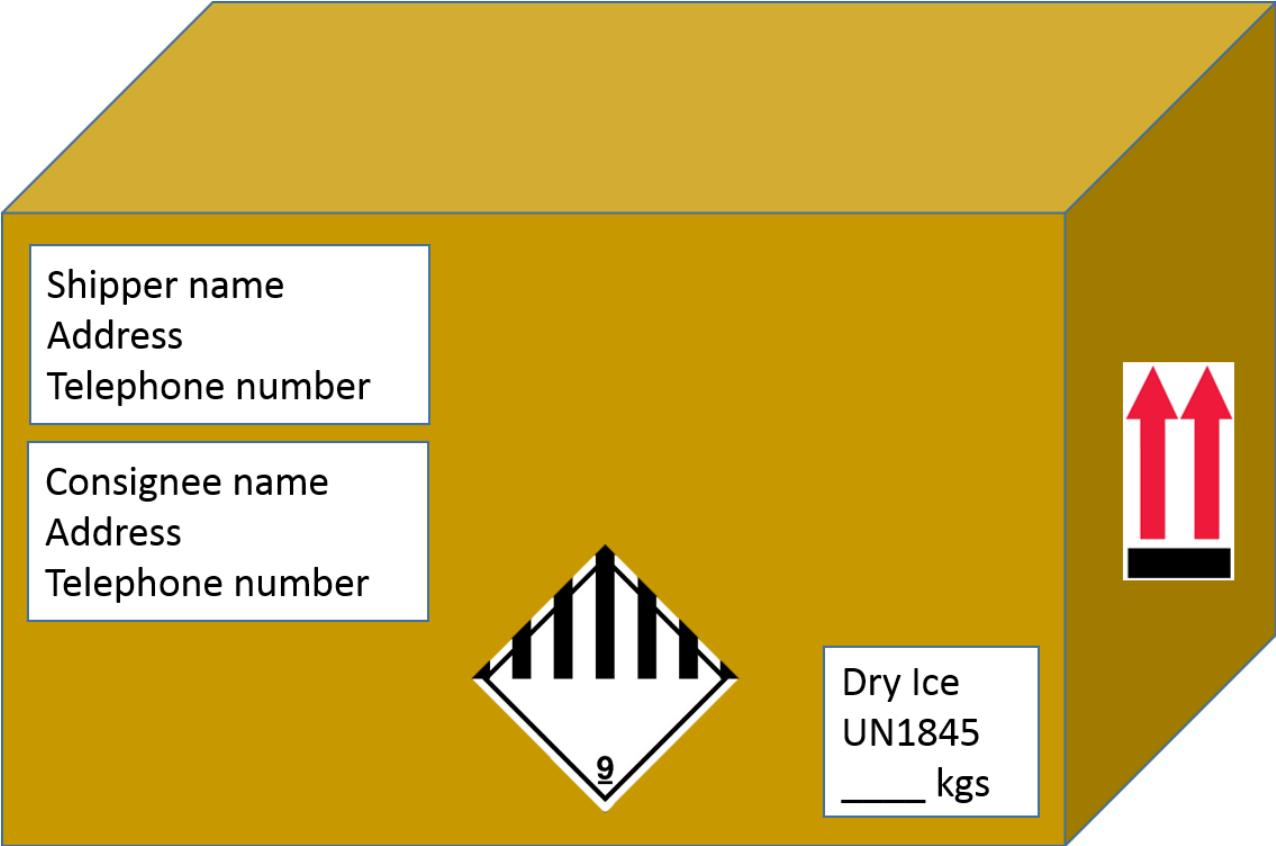

Flow Chart for Determining Classification of Biological Material

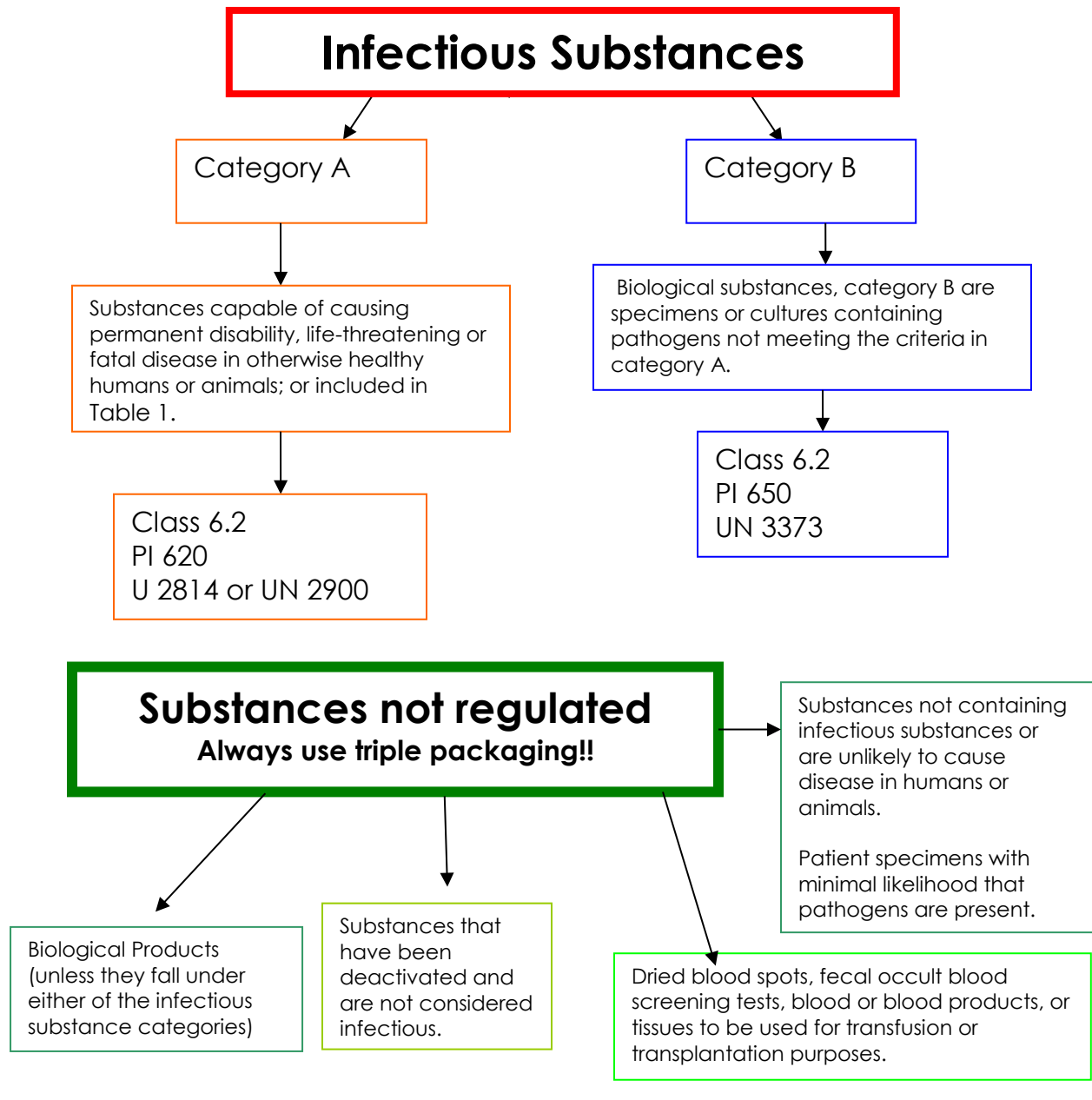

**Genetically modified organisms (GMOs)**

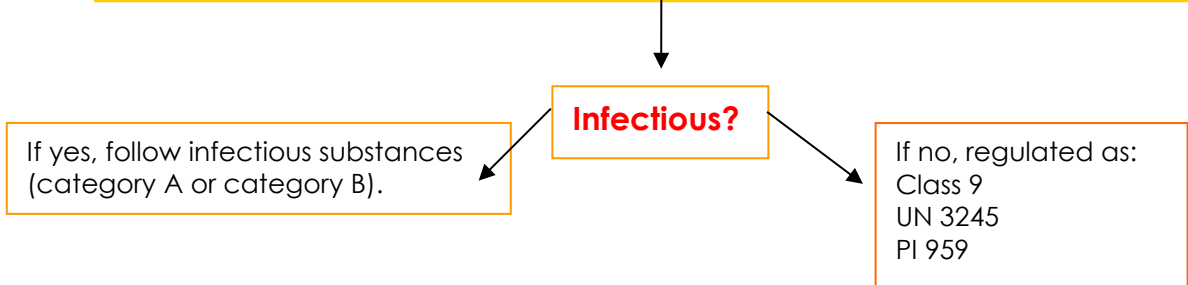

## E. Documentation

The proper declaration of dangerous goods by the shipper insures that all in the transportation chain know what kind of dangerous goods they are transporting, how to properly load and handle them and what to do if an incident or accident occurs either in flight or on the ground.

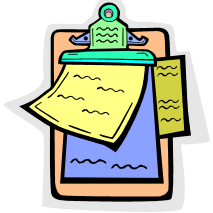

Required Documentation: For the IATA regulations, a “Shipper’s Declaration for Dangerous Goods” form and an “Air Waybill” must be completed for each consignment of dangerous goods.

**All completed Shipper’s Declaration forms must be FAXed (215-898-0140) or emailed to EHRS ([ehrs@ehrs.upenn.edu](mailto:ehrs@ehrs.upenn.edu)) for approval before the package is shipped! This is to ensure the declaration is completed correctly and the information is accurate. *If using eShip, we will be notified automatically.* Please contact EHRS at 215-898-4453 with any questions regarding the completion of the Shippers Declaration for Dangerous Goods.**

### 1. Shippers Declaration for Dangerous Goods

- **If using eShip, a Shippers Declaration will be generated automatically**
  - A Shippers Declaration for Dangerous Goods must be completed when shipping a Category A Infectious Substance assigned to UN 2814 or UN 2900.
  - The red hatching on the Shippers Declaration for Dangerous Goods is an indication that the item being shipped is a Dangerous Good. Forms for domestic and international transport are different.
  - A Shippers Declaration for Dangerous Goods is not required for shipments of Biological Substance, Category B assigned to UN 3373, shipments containing ONLY dry ice, and shipments with Excepted Quantities.
  - Declarations must be typewritten or computer-generated; handwritten declarations will not be accepted.
  - **Always print at least four copies: provide three to the carrier and keep one for your records for 2 years.**
  - Remember to sign and date each copy.
  - A completed sample of a shipper’s declaration can be found in [Appendix D](#).

**Regulations require that you must retain your copy of the Shippers Declaration for 2 years.**

**Important!!! Improperly completed shipper's declarations are the most common cause of package refusal. The Shipper's Declaration must be:**

- **Accurate**
- **Complete**
- **Legible**
- **Unaltered**

A change may be made on the form only if it is signed by the shipper with a full signature. No whiteout is allowed!

The following is an explanation for each section appearing on the "Shippers Declaration for Dangerous Goods" form: ([Appendix D](#))

- a. **Shipper:** Enter the full name, address and telephone number of the person packing this shipment. **THIS PERSON MUST BE TRAINED!** The address must also include the University of Pennsylvania.

**Example:** University of Pennsylvania  
Jenna Brown  
215-746-6666  
1234 Research Blvd  
Microbiology Laboratory  
Philadelphia, PA 19104

- b. **Consignee:** Enter full name, address, and phone number of recipient.

**Example:** Mycology Laboratory  
Dr. Sal M Nela  
654-213-8476  
University of Florida  
Gainesville, FL 21345

- c. **Transport Details:** Indicate here if your shipment is restricted to cargo aircraft only (if it is more than 50 ml or 50 g of an Infectious Substance). Airport of departure and airport of destination will be filled out by the carrier, leave blank.
- d. **Shipment Type:** Cross out "Radioactive" to indicate the shipment of a non-radioactive substance. If radioactive you must contact EHRS 215-898-7187 for additional instructions.
- e. **UN or ID Number:** Enter appropriate UN number as found in [Table 3](#).
- f. **Proper Shipping Name:** Enter the proper shipping name exactly as it appears in [Table 3](#). When the infectious substances to be transported are unknown but suspected of meeting the criteria for inclusion in Category A and assignment to UN 2814 or UN 2900, the words "Suspected Category A Infectious Substance" must be shown in parentheses following the proper shipping name.

**Example:** Infectious substance, affecting humans (Suspected Category A Infectious Substance)

**OR**

Infectious substance, affecting humans (Hendra Virus)

- g. **Class or Division:** Enter appropriate hazard class as found in [Table 3](#).
- h. **Packing Group:** For Dry Ice, enter "III" in this column. Infectious substances are not assigned packing groups.

- i. **Quantity and Type of Packaging:** Enter the net quantity for each material here. Use only *metric* units. At the bottom of the column, indicate the number and type of packages used (usually, "All packed in one fibreboard box." \*note the spelling). If using an overpack, state "Overpack Used".  
  
**Example:** 30 ml (if packaged in one primary container)  

**or**

15 ml X 2 (if packaged in two primary containers).
- j. **Packing Instructions:** Enter appropriate packing instruction number found in [Table 3](#).
- k. **Authorization:** Leave this column blank.
- l. **Additional Handling Instructions:** Leave this field blank if using the Chemtel number.
- m. **Emergency Telephone Number:** An emergency contact number must put in this area. It is imperative that the number given can be answered 24 hours a day until the package is delivered. This is a precaution in case of an emergency such as a spill.
- n. **Certification Statement:** The bottom of the Shipper's Declaration for Dangerous Goods must state "*I declare that all of the applicable air transport requirements have been met*". If this is not printed on the declaration, you must write it in
- o. **Name/Title of Signatory:** Name and title of the person signing the declaration.  

**This person must be trained!**
- p. **Place and Date:** Place and Date of signing the declaration.
- q. **Signature:** The shipper must sign this document.

**eShip Users:**

The following information will automatically appear on the Dangerous Goods Declaration when using the eShip program.

**Emergency Contact: CHEMTEL 1-800-255-3924 (1+813-248-0585 international)**  
Contract#:MIS5858352

**This number must be used by anyone from the University of Pennsylvania that will be shipping Dangerous Goods.**

*University has a contract with CHEMTEL to provide 24-hour emergency telephone response service.*

**A copy of the completed Shippers Declaration must be sent to CHEMTEL at least 24-hours prior to the shipment being sent.**

To forward SHIPPING DOCUMENTS, use: [UPEHRS@CHEMTELINE.COM](mailto:UPEHRS@CHEMTELINE.COM)

To forward SAFETY DATA SHEETS, use: [SDS@chemtelinc.com](mailto:SDS@chemtelinc.com)



## 2. Air Waybill

(UPS will NOT SHIP Infectious Substance, Category A!!)

(**eShip users:** the air waybill is completed for you within the program)

- a. Infectious substance, Category A
  - i. For an infectious substance, under “Handling Information” on the Air waybill, state “Dangerous Goods per attached Shipper’s Declaration for Dangerous Goods” or “Dangerous Goods per attached Shipper’s Declaration for Dangerous Goods Cargo Aircraft only”.
- b. Biological substance, Category B
  - i. The name, address and phone number of the responsible person must be on this document if it is not on the box.

*NOTE: The phone number of the responsible person can be the shipper, consignee, or a third party that is knowledgeable about the shipment. The number must be available during regular business hours in case of questions or problems.*
  - ii. Dry Ice must appear as the following: (Dry Ice UN 1845 X kg)
  - iii. The “Nature and Quantity Goods” box must show the text “BIOLOGICAL SUBSTANCE, CATEGORY B” and UN 3373.
- c. Exempt specimens
  - i. The “Nature and Quantity Goods” box must show the text “Exempt animal specimen” or “Exempt human specimen”.
- d. Dry Ice
  - i. The “Nature and Quantity Goods” box must show the text “Dry Ice UN 1845 X kg”.
- e. Excepted Quantities
  - i. The “Nature and Quantity Goods” box must show the text “Dangerous Goods in Excepted Quantities”.
- f. Dry Shipper
  - i. **eShip users:** select Dry Shipper as the package type
  - ii. The “Nature and Quantity Goods” box must show the text “not restricted” and “A152”.
- g. Liquid Nitrogen
  - i. The “Nature and Quantity Goods” box must show the text “UN1977 Nitrogen, refrigerated liquid”.

## **Part III. Special Regulations**



### **A. Select Agents**

### **B. Importing and Exporting Infectious Substances**

## **A. Special Regulations for Select Agents**

In 2003 the federal government designated certain biological agents and toxins as Select Agents based on their potential to pose a threat to the public health.

Select Agents are regulated by the Centers for Disease Control and Prevention (CDC) and the Animal Plant Health Inspection Service (APHIS).

Select Agents and Toxins List: See Table 4 for a complete list of Select Agents and Toxins. The list is also available at <https://www.selectagents.gov/selectagentsandtoxinslist.html>.

**Possession, use and/or transfer of Select Agents must be registered with EHRs and CDC or APHIS *prior* to bringing the materials to Penn's campus.**

All Select Agent transfers must be authorized in writing by the director of EHRs prior to the transfer. Additional shipping requirements and restrictions apply to Select Agents. They are not discussed in this manual. **Contact EHRs for assistance with Select Agents. Also visit [www.cdc.gov/od/sap/](http://www.cdc.gov/od/sap/)**

## B. Import and Export of Biological Materials & Infectious Substances

The import or export of animals, animal-derived materials, insects, etiologic agents, biological toxins, or genetically-modified organisms may require a federal permit from the CDC, United States Department of Agriculture (USDA), or the US Fish and Wildlife Services (USFWS). An export license from the Departments of Commerce, State, and Treasury may also be required.

### International Shipments

Shipping and receiving animals and animal-derived materials, infectious or biohazardous agents, biological toxins, and genetically modified organisms may require the approval of federal agencies, both domestic and foreign. Regulations that govern the transfer of biological materials help to minimize or eliminate the possible threats to public health and agriculture.

Packages shipped internationally generally require increased preparation time due to the additional paperwork required. An import/export permit may be required when shipping biological materials internationally. Check with U.S. governmental agencies for permits and additional information.

**Countries may change their import requirement without notice!!**

## 1. Import and Export Permits:

### CDC

A permit is required to import biological agents or vectors of human disease, which includes bats, bat specimens and non-human specimens, into the U.S. from another country and to transport interstate.

**Import Permit Program (IPP):** <http://www.cdc.gov/od/eaipp/importapplication/agents.htm>

**Do you need an import permit?**

**IPP Tool:** <http://www.selectagents.gov/resources/IPPetool/>

**Frequently asked questions:** <http://www.cdc.gov/od/eaipp/faq.htm>

**When a CDC permit is NOT required:**

- If the material being imported has been rendered sterile (e.g., thermal, chemical, or irradiation treatment) or it has been confirmed not to contain infectious agents for humans.

**Documentation stating this is required!**

**Other materials that *do not* require a CDC issued import permit include:**

- Select agents listed in 42 CFR Part 73 if its importation has been authorized in accordance with 42 CFR 73.16 or 9 CFR 121.16.
- Diagnostic specimen not known by the importer to contain, or suspected by the importer of containing, an infectious biological agent and is accompanied by an importer certification statement confirming that the material is not known to contain or suspected of containing an infectious biological agent, or has been rendered noninfectious **Include documentation with the shipping papers.**

## Special Regulations – Import and Export

- Animal or animal product being imported for educational, exhibition, or scientific purposes and is accompanied by documentation confirming that the animal or animal product is not known to contain (or suspected of containing) an infectious biological agent or has been rendered noninfectious.
- Nucleic acids that cannot produce infectious forms of any infectious biological agent and the specimen is accompanied by an importer certification statement confirming that the material is not known to contain or suspected of containing an infectious biological agent.
- Animal or animal product listed in 42 CFR Part 71 if its importation has been authorized in accordance with 42 CFR §§ 71.52, 71.53, or 71.56.
- Product that is cleared, approved, licensed, or otherwise authorized under any of the following laws:
  - The Federal Food, Drug, and Cosmetic Act (21 U.S.C. § 301 et seq.), or
  - Section 351 of the Public Health Service Act pertaining to biological products(42 U.S.C. § 262), or
  - The Virus-Serum-Toxin Act (21 U.S.C. §§ 151-159).

### **Importer or Exporter Certification Statement:**

**Please Note:** The CDC requires that importers of materials that do not require a CDC import permit, include with the shipment an **importer certification statement** confirming that the material is not known to contain or suspected of containing an infectious biological agent, or has been rendered noninfectious. See [Appendix F](#) for a template letter.

### **The certification statement must include:**

- A detailed description of the material; and
- A statement on official letter head signed by the person responsible for the shipment clearly stating that (1) the material is not known or suspected to contain an infectious biological agent and (2) how the person making the certification knows that the specimen does not contain an infectious biological agent; or the basis of the belief that there is no reason to suspect that the specimen does not contain an infectious biological agent; or a detailed description of how the material was rendered noninfectious.

## **USDA/APHIS**

### **Imports (into the United States)**

APHIS issues permits for the import, transit and release of regulated animals, animal products, veterinary biologics, plants, plant products, pests, organisms, soil, and genetically engineered organisms.

Permits: <https://www.aphis.usda.gov/wps/portal/aphis/ourfocus/importexport>

### **Exports (into other countries)**

Import permits are usually required for materials of animal origin. Please check with the recipient to ensure they have the proper import permits. This will vary from country to country.

**A USDA Health Certificate may be required for exporting some animal material:**

**VS Form 16-4** (<https://www.aphis.usda.gov/aphis/ourfocus/animalhealth/export/iregs-for-animal-product-exports>)

### **U.S. Fish and Wildlife**

The U.S. Fish and Wildlife issues permits under various wildlife laws and treaties at different offices at the national, regional, and /or wildlife port levels. Permits are issued to the individual.

Permits enable the public to engage in legitimate wildlife-related activities that would otherwise be prohibited by law. The permit programs ensure safeguarding wildlife and promote conservation efforts by authorizing scientific research, generating data, or allowing wildlife management and rehabilitation activities to go forward.

**A CITES permit is required for all nonhuman primate tissues or tissues from any endangered species.** Forms may need an institutional authority signature. Reach out to EHRS for details.

Permits: <http://www.fws.gov/permits/overview/overview.html>

## 2. Export Control Laws:

Export Control Laws (ECLs) are a complex set of federal regulations designed to protect U.S. national security; to prevent the proliferation of weapons of mass destruction; to further U.S. foreign policy including the support of international agreements, human rights and regional stability; and to maintain U.S. economic competitiveness.

All materials shipped out of the United States are subject to ECLs including the International Traffic in Arms Regulations (ITAR), and the Export Administration Regulations (EAR).

Do you need a permit to export biological materials?

- a. Check with the country you are shipping to.
  - b. Give as much information as possible to prevent materials being held in Customs.
    1. Commercial Invoice
    2. Certification Statement (see template letter in [Appendix F](#))
- \*If shipping bovine serum, submit documentation from the company.

Office of Research Services: <http://www.upenn.edu/researchservices/exportcontrols.html>

U.S. Department of Commerce: <http://www.bis.doc.gov/index.php/regulations/commerce-control-list-ccl>

U.S. Department of State: [http://www.pmdtdc.state.gov/regulations\\_laws/itar.html](http://www.pmdtdc.state.gov/regulations_laws/itar.html)

## 3. Commercial Invoice/Customs Invoice

- All International shipments will require a Commercial Invoice or Customs Invoice.
  - **eShip users:** the description you enter under “**Material Name**” will become the wording for the description of the goods in the **Commercial Invoice**. Print out this document along with the shipping papers.
  - If you are using another program for UPS, FedEx, DHL, or World Courier, they will be provided with their paper work.

## Part IV.

# Shipping Company Limitations and Private Transport

Some shipping companies may have rules that are more restrictive than those discussed in this document. See IATA 2.8.4 List of Operator Variations for a complete list of variations from the regulations. Consider the following details before planning a shipment:

### A. United States Postal Service (USPS)

- **Infectious substances, category A** will **not** be accepted.
- **Biological substances, category B**, if packaged and labeled according to the requirements listed in this manual for category B shipments, may be mailed as First-Class Mail, Priority Mail, or Express Mail.

Please check their website for more information:

#### **Publication 52, Hazardous, Restricted, and Perishable Mail**

(<http://pe.usps.com/text/pub52/welcome.htm>)

#### **UPS Guide for Shipping Ground and Air Hazardous Materials**

(<http://ups.com/hazmat>)

- **Genetically modified organisms** or **Genetically modified micro-organisms** are not accepted in UPS small package services
- **Exempt human and animal specimens** can be mailed provided packaging and labeling follow the requirements listed in this manual for exempt human and animal specimens.

**Outer packaging must be rigid**

**Total volume per package is limited to 500ml or 500g**

### B. FedEx Corporation (FedEx)

- Fed Ex Express and Fed Ex Ground will accept shipments prepared according to instructions in this manual. Fed Ex will not accept any material considered to be in Risk Group 4. Please refer to the EHRS Biosafety Manual for the definition of Risk Groups.

### C. United Postal Service (UPS)

- Fed Ex Express and Fed Ex



#### **D. DHL Express**

- DHL will accept shipments in accordance with IATA or DOT regulations. Shipments made according to instructions in this manual will be acceptable to DHL.

#### **E. Transport by private or contract carrier exemption**

- Any biological specimens, which includes patient samples, that are being shipped for research, diagnosis, investigational activities or disease treatment and prevention are exempt from the IATA and DOT regulations when being transported by a private or contract carrier as long as the motor vehicle being used is exclusively for transport of these materials. Infectious substances, Category A materials are NOT included in this exemption.

## **Part V. Emergency Response for an Infectious Substance in Transport**

**The best advice to give in case of an emergency:**

- 1. Stay upwind.**
- 2. Keep unauthorized personnel away.**
- 3. Do not allow anyone to touch or walk through spilled material.**
- 4. Do not allow clean-up of the spill or disposal of the material except under the supervision of an expert.**

**If you are receiving a package:**

- 1. Inspect the package before signing for it.**
- 2. Do not accept damaged or leaking packages.**
- 3. Packages are the responsibility of the shipper until the receiver (YOU) accept them!!!**

## Part VI. Summary

### Things to remember

1. Identify your shipment correctly!! Classify, Mark and Label!

#### 2. TRAINING!

If you are involved with shipping and put your name on the package as the "shipper", you absolutely must be trained. An individual, as well as the institution, can be fined and put in jail if the regulations are not followed. That means, if you ship and have your name specified as the shipper, you are responsible to go through the training!!

3. Keep your training certificate on file.

4. Check EHRS website for updates.

5. Refresher training every 2 years.

6. Use **Chemtel** for the emergency phone number.

*1(800) 255-3924 (1+ 813 248-0585 international) Contract # MIS5858352*

7. After completion of the Shipper's Declaration for Dangerous Goods, FAX to EHRS for approval. (EHRS FAX number: 215-898-0140)

8. Keep Shipper's Declaration for Dangerous Goods on file for 2 years.

9. Know the exemptions!

**Sweat the details!!**



10. Follow this manual for packaging and documenting your hazardous good shipment.

Remember, shipping hazardous chemicals and radioactive materials within and outside of the United States is subject to a variety of government regulations, airline industry regulations, and ground carriers' requirements. Do not hesitate to ask for assistance! Contact the Office of Environmental Health and Radiation Safety with any questions.

A special thank you to Andy Globe, University of New Hampshire.

**Table 1. The Category A List**

**This table is not exhaustive. Infectious substances, including new or emerging pathogens, which do not appear in the table but which meet the same criteria must be assigned to Category A. In addition, if there is doubt as to whether or not a substance meets the criteria it must be included in Category A.**

UN Number and Proper Shipping Name	Microorganism
UN 2814 Infectious substance affecting humans	<i>Bacillus anthracis</i> (cultures only)
	<i>Brucella abortus</i> (cultures only)
	<i>Brucella melitensis</i> (cultures only)
	<i>Brucella suis</i> (cultures only)
	<i>Burkholderia mallei</i> - <i>Psuedomonas mallei</i> -Glanders (cultures only)
	<i>Burkholderia pseudomallei</i> - <i>Psuedomonas pseudomallei</i> (cultures only)
	<i>Chlamydia psittaci</i> -avian strains (cultures only)
	<i>Clostridium botulinum</i> (cultures only)
	<i>Coccidioides immitis</i> (cultures only)
	<i>Coxiella burnetti</i> (cultures only)
	Crimean-Congo hemorrhagic fever virus
	Dengue virus (cultures only)
	Eastern equine encephalitis virus (cultures only)
	<i>Escherichia coli</i> , verotoxigenic (cultures only)
	Ebola virus
	Flexal virus
	<i>Francisella tularensis</i> (cultures only)
	Guanarito virus
	Hantaan virus
	Hantaviruses causing hemorrhagic fever with renal syndrome
	Hendra virus
	Hepatitis B virus (cultures only)
	Herpes B virus (cultures only)
	Human immunodeficiency virus (cultures only)
	Highly pathogenic avian influenza virus (cultures only)
	Japanese Encephalitis virus (cultures only)
	Junin virus
	Kyasanur Forest disease virus
	Lassa virus
	Machupo virus
	Marburg virus
	Monkeypox virus
	<i>Mycobacterium tuberculosis</i> (cultures only)
	Nipah virus
	Omsk hemorrhagic fever virus
	<i>Poliovirus</i> (cultures only)
	Rabies virus (cultures only)
	<i>Rickettsia prowazekii</i> (cultures only)
	<i>Rickettsia rickettsii</i> (cultures only)
	Rift valley fever virus (cultures only)
	<i>Russian spring-summer encephalitis virus</i> (cultures only)
Sabia virus	
<i>Shigella dysenteriae type 1</i> (cultures only)	
<i>Tick-borne encephalitis virus</i> (cultures only)	
Variola virus [i.e. Small Pox]	
Venezuelan equine encephalitis virus (cultures only)	
<i>West Nile virus</i> (culture only)	
<i>Yellow fever virus</i> (cultures only)	
<i>Yersinia pestis</i> (cultures only)	

UN Number and Proper Shipping Name	Microorganism
UN 2900 Infectious substances affecting animals	African swine fever virus (cultures only)
	Avian paramyxovirus Type 1 – Velogenic Newcastle disease virus (cultures only)
	Classical swine fever virus (cultures only)
	Foot and mouth disease virus (cultures only)
	Goatpox virus (cultures only)
	Lumpy skin disease virus (cultures only)
	<i>Mycoplasma mycoides</i> -ContagiousContagious bovine pleuropneumonia (cultures only)
	Peste des petits ruminants virus (cultures only)
	Rinderpest virus (cultures only)
	Sheep-pox virus (cultures only)
	Swine vesicular disease virus (cultures only)
	Vesicular stomatitis virus (cultures only)

## Category B

An infectious substance which does not meet the criteria for inclusion in the Category A List must be assigned to UN 3373.

**Table 2. Comparison of PI 650 and 620**

<b>Feature</b>	<b>PI 650</b>	<b>PI 620</b>
Primary container	Present	Present
Secondary container	Present	Present
Outer container	Present	Present
Absorbent material for entire contents	Present	Present
United Nations design type testing* (performance requirements)		
1.2 m drop test	Must pass	Must pass
9 m drop test	Not required	Must pass
Puncture test	Not required	Must pass
Water immersion test	Not required	Must pass
Test reports	Should be available	Must be available
UN specification mark	Not required	Required
Minimum dimensions	Not defined	Defined
Volume and weight restrictions	Not defined	Defined
Packaging size restrictions	Not defined	Defined
*PI 650 packages are not required to meet UN performance requirements provided they pass a 1.2m drop test.		
Pressure testing of either primary or secondary containers for both PI 602 and PI 650 must pass requirements of withstanding, without leakage, an internal pressure producing a pressure differential of not less than 95 kPa and temperatures in the range of -40°C to +55°C (-40°F to 130°F).		

**Table 3: Summary of Shipping Information**

Shipment Type	Proper Shipping Name	UN Number	Hazard Class	Packing Group (PG)	Packing Instruction (PI)	Max. Net qty/pkg for Passenger Aircraft	Max. Net qty/pkg for Cargo Aircraft
Category A infectious substance, affecting humans	Infectious substance, affecting humans (technical name)	UN 2814	6.2	-	620	50 ml or 50 g	4 L or 4 kg
Category A infectious substance, affecting animals	Infectious substance, affecting animals (technical name)	UN 2900	6.2	-	620	50 ml or 50 g	4 L or 4 kg
Category B infectious substance	Biological substance, category B	UN 3373	6.2	-	650	4 L or 4 kg	4 L or 4 kg
Dry Ice	Dry Ice or Carbon Dioxide, solid	UN 1845	9	-	954	200 kg	200 kg
Non-infectious, GMOs	Genetically Modified Micro-organisms	UN 3245	9	-	959	No limit	No limit
Infectious GMOs	Infectious substance, affecting humans ( ) OR Infectious substance, affecting animals ( )	UN 2814 Or UN 2900 Or UN 3373	6.2	-	620  650	50 mL or 50 g	4L or 4 kg
Patient Specimens	"Exempt human specimens" or "Exempt animal specimens"	-	-	-	Triple packaging	Primary receptacle (500ml or 500g) Outer packaging (4L or 4kg)	Primary receptacle (500ml or 500g) Outer packaging (4L or 4kg)

**Table 4: Select Agents and Toxins List**

<b>HHS AND USDA Select Agents AND TOXINS</b> <b>7 CFR Part 331, 9 CFR Part 121, and 42 CFR Part 73</b>	
<p><b><u>HHS SELECT AGENTS AND TOXINS</u></b></p> <p>Abrin  <i>Bacillus cereus</i> Biovar <i>anthracis</i>*            Botulinum neurotoxins*            Botulinum neurotoxin producing species of <i>Clostridium</i>*            Conotoxins (Short, paralytic alpha conotoxins containing the following amino acid sequence X<sub>1</sub>CCX<sub>2</sub>PACGX<sub>3</sub>X<sub>4</sub>X<sub>5</sub>X<sub>6</sub>CX<sub>7</sub>)<sup>1</sup>  <i>Coxiella burnetii</i>            Crimean-Congo haemorrhagic fever virus            Diacetoxyscirpenol            Eastern Equine Encephalitis virus<sup>3</sup>            Ebola virus*  <i>Francisella tularensis</i>*            Lassa fever virus            Lujo virus            Marburg virus*            Monkeypox virus<sup>3</sup>            Reconstructed replication competent forms of the 1918 pandemic influenza virus containing any portion of the coding regions of all eight gene segments (Reconstructed 1918 Influenza virus)            Ricin  <i>Rickettsia prowazekii</i>            SARS-associated coronavirus (SARS-CoV)            Saxitoxin            South American Haemorrhagic Fever viruses:                Chapare                Guanarito                Junin                Machupo                Sabia            Staphylococcal enterotoxins A,B,C,D,E subtypes            T-2 toxin            Tetrodotoxin            Tick-borne encephalitis complex (flavi) viruses:                Far Eastern subtype                Siberian subtype            Kyasanur Forest disease virus            Omsk hemorrhagic fever virus            Variola major virus (Smallpox virus)*            Variola minor virus (Alastrim)*  <i>Yersinia pestis</i>*</p>	<p><b><u>OVERLAP SELECT AGENTS AND TOXINS</u></b></p> <p><i>Bacillus anthracis</i>*  <i>Bacillus anthracis</i> Pasteur strain  <i>Brucella abortus</i>  <i>Brucella melitensis</i>  <i>Brucella suis</i>  <i>Burkholderia mallei</i>*  <i>Burkholderia pseudomallei</i>*            Hendra virus            Nipah virus            Rift Valley fever virus            Venezuelan equine encephalitis virus<sup>3</sup></p> <p><b><u>USDA SELECT AGENTS AND TOXINS</u></b></p> <p>African horse sickness virus            African swine fever virus            Avian influenza virus<sup>3</sup>            Classical swine fever virus            Foot-and-mouth disease virus*            Goat pox virus            Lumpy skin disease virus  <i>Mycoplasma capricolum</i><sup>3</sup>  <i>Mycoplasma mycoides</i><sup>3</sup>            Newcastle disease virus<sup>2,3</sup>            Peste des petits ruminants virus            Rinderpest virus*            Sheep pox virus            Swine vesicular disease virus</p> <p><b><u>USDA PLANT PROTECTION AND QUARANTINE (PPQ) SELECT AGENTS AND TOXINS</u></b></p> <p><i>Peronosclerospora philippinensis</i>  <i>(Peronosclerospora sacchari)</i>  <i>Phoma glycinicola</i> (formerly  <i>Pyrenochaeta glycines)</i>  <i>Ralstonia solanacearum</i>  <i>Rathayibacter toxicus</i>  <i>Sclerophthora rayssiae</i>  <i>Synchytrium endobioticum</i>  <i>Xanthomonas oryzae</i></p>



\*Denotes Tier 1 Agent

<sup>1</sup> C = Cysteine residues are all present as disulfides, with the 1st and 3rd Cysteine, and the 2nd and 4th Cysteine forming specific disulfide bridges; The consensus sequence includes known toxins  $\alpha$ -MI and  $\alpha$ -GI (shown above) as well as  $\alpha$ -GIA, Ac1.1a,  $\alpha$ -CnIA,  $\alpha$ -CnIB; X1 = any amino acid(s) or Des-X; X2 = Asparagine or Histidine; P = Proline; A = Alanine; G = Glycine; X3 = Arginine or Lysine; X4 = Asparagine, Histidine, Lysine, Arginine, Tyrosine, Phenylalanine or Tryptophan; X5 = Tyrosine, Phenylalanine, or Tryptophan; X6 = Serine, Threonine, Glutamate, Aspartate, Glutamine, or Asparagine; X7 = Any amino acid(s) or Des X and; "Des X" = "an amino acid does not have to be present at this position." For example if a peptide sequence were XCCHPA then the related peptide CCHPA would be designated as Des-X.

<sup>2</sup> A virulent Newcastle disease virus (avian paramyxovirus serotype 1) has an intracerebral pathogenicity index in day-old chicks (*Gallus gallus*) of 0.7 or greater or has an amino acid sequence at the fusion (F) protein cleavage site that is consistent with virulent strains of Newcastle disease virus. A failure to detect a cleavage site that is consistent with virulent strains does not confirm the absence of a virulent virus.

<sup>3</sup> Select agents that meet any of the following criteria are excluded from the requirements of this part: Any low pathogenic strains of avian influenza virus, South American genotype of eastern equine encephalitis virus, west African clade of Monkeypox viruses, any strain of Newcastle disease virus which does not meet the criteria for virulent Newcastle disease virus, all subspecies *Mycoplasma capricolum* except subspecies *capripneumoniae* (contagious caprine pleuropneumonia), all subspecies *Mycoplasma mycoides* except subspecies *mycoides* small colony (Mmm SC) (contagious bovine pleuropneumonia), and any subtypes of Venezuelan equine encephalitis virus except for Subtypes IAB or IC, provided that the individual or entity can verify that the agent is within the exclusion category. 9/10/13

## Appendix A

### Manufactures of Certified Shipping Containers for Infectious substances, Biological substances and Dry Ice

DG Supplies, Inc.  
5 Boxal Drive  
Cranbury, NJ 08512  
Phone: 800-347-7879  
<http://www.dgsupplies.com>

Inmark, Inc.  
220 Fisk Drive S.W.  
Atlanta, GA 30336-0309  
Phone: 800-646-6275  
<http://www.inmarkinc.com>

SAF-T-PAK, Inc.  
7466 Candlewood Road, Suite E  
Hanover, MD 21076  
Phone: 800-814-7484  
<http://www.saftpak.com>

Therapak (through Fisher Scientific)  
300 Industry Drive  
Pittsburgh, PA 15275 USA  
Phone: 724-517-1500  
<https://www.fishersci.com>

Casing Scientific  
5015 Addison Circle  
Addison, Texas  
Phone: 800-358-6866  
<http://www.casing.corp.com>

Exakt-Pak  
7002 N Broadway Ext.  
Oklahoma City, OK 73116-9006  
Phone: 800-866-7172  
<http://www.exaktpak.com>

CARGOpak Corporation  
3215-A Wellington Court  
Raleigh, NC 27615  
Phone: 800-266-0652  
<http://www.cargopak.com>

HAZMATPAC, Inc  
5301 Polk St., Bldg 18  
Houston, TX 77023  
Phone: 800-347-7879  
<http://www.hazmatpac.com>

## Appendix B

### UN Specification Marking for Infectious Substances, Category A

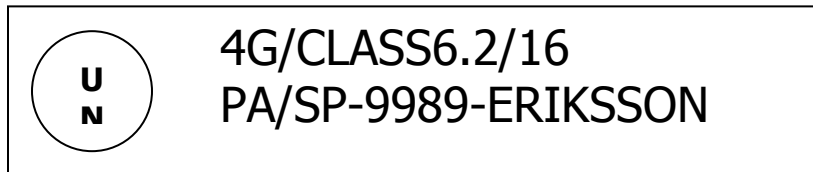

UN = United Nations

4 = box, G = fiberboard

CLASS6.2 = meets performance testing for Category A

16 = year box was made

PA = state

SP-9989-ERIKSSON = manufacturer

This marking must be on boxes being used for shipping Infectious Substances unless using an overpack. When using an overpack, the outer box must be marked "Overpack". This indicates that packages on the inside comply with prescribed specifications.

### Performance Testing

Each primary or secondary container must have passed the performance testing required by the UN. The primary receptacle or secondary container must be capable of withstanding, without leakage, an internal pressure producing a pressure differential of not less than 95 kPa and temperatures in the range of -40°C to +55°C (-40°F to 130°F).

The following are also performance tests for the primary and or secondary containers:

- ✓ Drop test
  - PI 620 for Infectious Substances must pass a drop of 9 m
  - PI 650 for Diagnostic Specimens must pass at least a 1.2 m drop
- ✓ Puncture test
  - PI 620 must pass puncture tests
- ✓ Water immersion test
  - PI 620 must pass water immersion testing

## Appendix C Triple Packaging

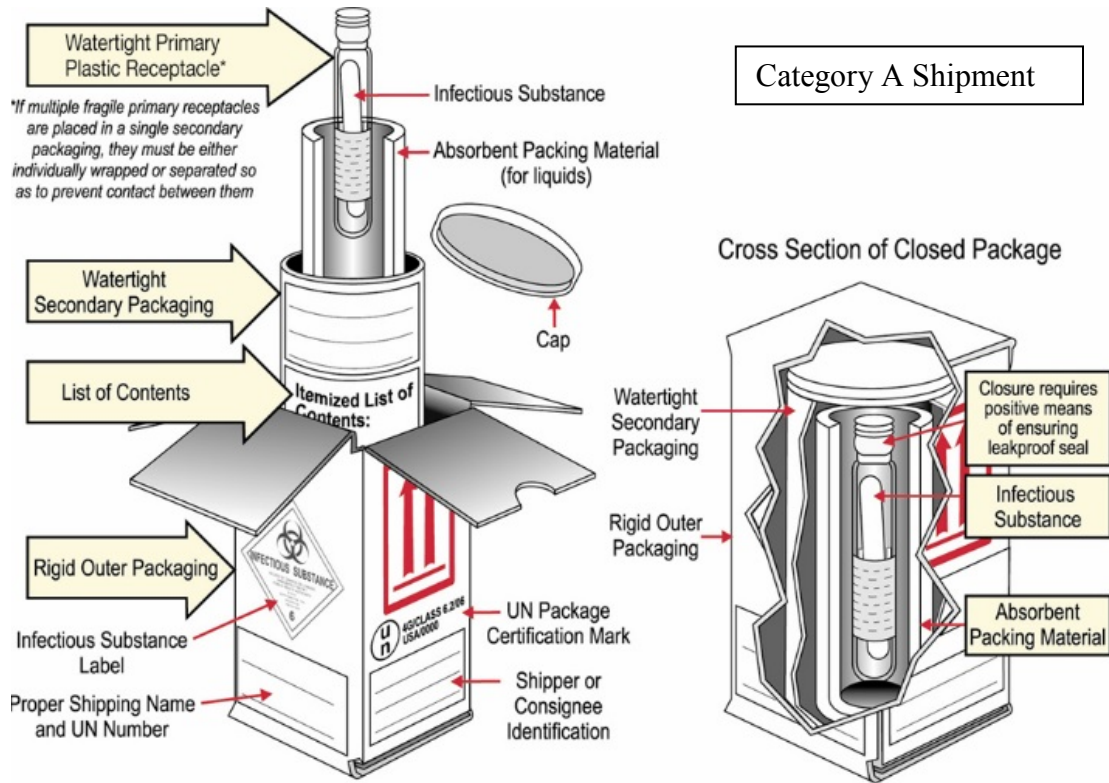

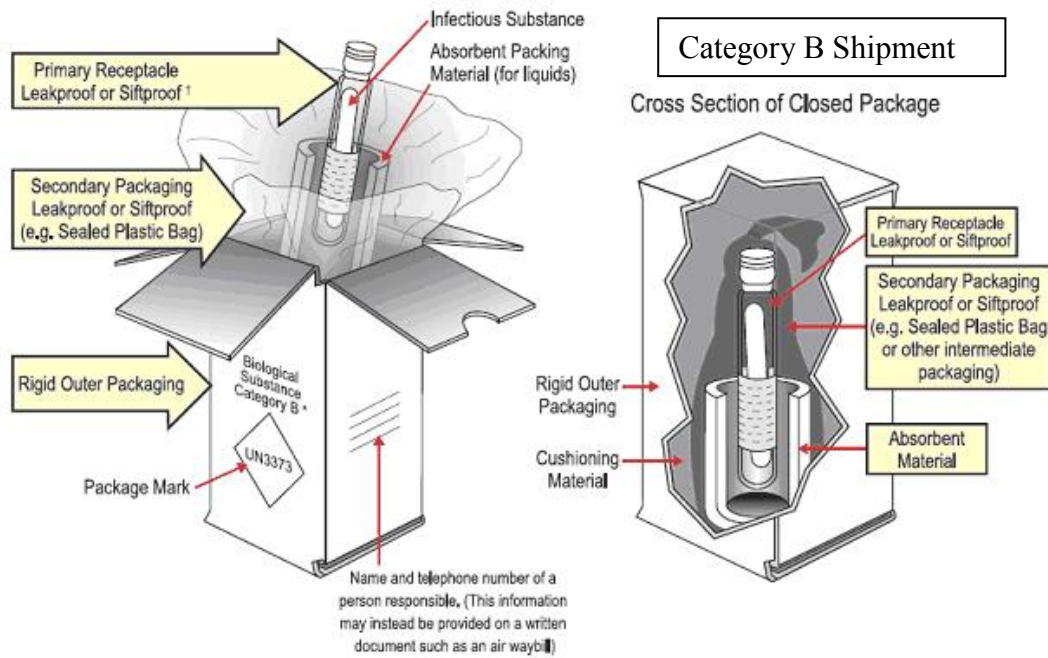

\* The proper shipping names "Biological Substance, Category B"; "Clinical Specimen"; and "Diagnostic Specimen" are authorized until December 31, 2006. From January 1, 2007 only the proper shipping name "Biological Substance, Category B" will be authorized.

† If multiple fragile primary receptacles are placed in a single secondary packaging they must be either individually wrapped or separated to prevent contact

**Note:** Follow package manufacturer's closure instructions

# APPENDIX D Shipper Declaration

SHIPPER'S DECLARATION FOR DANGEROUS GOODS

(Provide at least three copies to the operator)

**Shipper**

The University of Pennsylvania  
Marie-Luise Faber  
215-746-6706  
3160 Chestnut Street  
Suite 400  
Philadelphia, PA 19104  
United States

**Air WayBill No:** 788068739426

Page 1 of 1 pages

Shipper's Reference

**Consignee**

, Sue Souder  
111-222-3333  
3160 Chestnut Street  
Philly, PA 19104  
United States

Three completed and signed copies of this Declaration must be handed to the operator

Transport Details			
This shipment is within the limitations prescribed for: <i>(cross out non applicable)</i>	Airport of Departure		
<table border="1" style="width: 100%;"> <tr> <td style="width: 50%; text-align: center;"><b>PASSENGER AND CARGO AIRCRAFT</b></td> <td style="width: 50%; text-align: center;"><del>CARGO AIRCRAFT ONLY</del></td> </tr> </table>	<b>PASSENGER AND CARGO AIRCRAFT</b>	<del>CARGO AIRCRAFT ONLY</del>	
<b>PASSENGER AND CARGO AIRCRAFT</b>	<del>CARGO AIRCRAFT ONLY</del>		
Airport of Destination:			

**WARNING**

**Failure to comply in all respects with the applicable Dangerous Goods Regulations may be in breach of the applicable law, subject to legal penalties.**

Shipment type: *(cross out non-applicable)*  
**NON-RADIOACTIVE**    ~~RADIOACTIVE~~

**NATURE AND QUANTITY OF DANGEROUS GOODS**

Dangerous Goods Identification						
UN or ID No.	Proper Shipping Name	Class or Division (Subsidiary risk)	Packing Group	Quantity and type of packaging	Packing Inst.	Authorization
UN2814	Infectious substance, affecting humans (EBOLA VIRUS)	6.2		0.001 L	620	
UN1845	Dry Ice	9		3.6 Kg All packed in one Fibreboard Box	954	

**Additional Handling Information**

Person Responsible : Marie-Luise Faber 215-746-6706

**Emergency Telephone Number:**

Emergency 24-hr Chemtrec telephone number: 1-800-424-9300 Acct# CCN15532

<p>I hereby declare that the contents of this consignment are fully and accurately described above by the proper shipping name, and are classified, packaged, marked and labeled/placarded, and are in all respects in proper condition for transport according to applicable International and National Governmental Regulations. I declare that all of the applicable air transport requirements have been met.</p>	<p>Name/Title of Signatory Marie-Luise Faber (Researcher/Staff) Place and Date Philadelphia, PA 10/13/2017 Signature</p> <p><i>(see warning above)</i></p>
---	--

FOR RADIOACTIVE MATERIAL SHIPMENT ACCEPTABLE FOR PASSENGER AIRCRAFT, THE SHIPMENT CONTAINS RADIOACTIVE MATERIAL INTENDED FOR USE IN OR INCIDENT TO RESEARCH, MEDICAL DIAGNOSIS, OR TREATMENT. ADR EUROPEAN TRANSPORT STATEMENT: CARRIAGE IN ACCORDANCE WITH 1.1.4.2.1

## APPENDIX E

### Export controls on biological and chemical materials being sent out of the country

Do I need a license?

The transfer of biological and chemical materials outside of the country may trigger the need for an export license. In most cases, the transfer of such biological and chemical materials will be allowed without the need to apply for a license from the federal government. In some cases, however, a license may be required from the U.S. Department of Commerce, the U.S. Department of State, and/or the U.S. Department of the Treasury, depending upon: the nature and amount of the materials; to whom the materials are being sent; the destination; and the purpose for which the materials are being sent.

Examples of materials that may require a license include biological materials that could be used in chemical or biological weapons (pathogens, toxins, etc.). The lists of materials that could require a specific license application are contained in the applicable regulations. (To review the lists of biological and chemical materials that the Department of Commerce regulates for export control licenses, see <http://www.ecfr.gov/cgi-bin/retrieveECFR?gp=1&SID=2360f7537ad693251d52595768cda968&ty=HTML&h=L&n=15y2.1.3.4.45&r=PART>, particularly sections 1C350 through 1C360.)

In addition to the export controls described above based on the nature of the materials being transferred, there are regulations administered by the Department of the Treasury applying to exports going to specific countries, individuals or entities. Examples would include individuals the government has identified as being involved with terrorism, drug trafficking or other illicit activities. Countries against which the federal government has imposed trade sanctions and travel embargoes (such as Cuba, Iran, etc.) also have restrictions and might require applying for an export license before shipping materials. The lists are maintained by the federal government and need to be checked prior to shipping biological or chemical materials. (Links to the various government lists are available from the Office of Research Service's web site at <http://www.upenn.edu/researchservices/exportcontrols.html>).

Any individual planning to transfer materials should work with the University to check the regulations and, if necessary, apply for the appropriate license. Failure to do so may result in significant criminal and civil liabilities. You should contact the Office of Research Services as soon as possible, because the federal government can take significant time in determining whether to grant the export license. If you are transferring materials pursuant to an outgoing material transfer agreement, sponsored research agreement, clinical trial agreement, or other agreement negotiated and signed by the Office of Research Services, ORS will work with you in advance to determine whether an export license might be needed as part of performing the contract.

For information on export control matters, as well as contacts for additional information/guidance, please review the website of the Office of Research Services at <http://www.upenn.edu/researchservices/exportcontrols.html> or contact

Jessica Buchanan  
Associate Director, Export Compliance  
Office of Research Services  
University of Pennsylvania  
P-221 Franklin Building  
3451 Walnut Street  
Philadelphia, PA 19104-6205  
[expctrl@lits.upenn.edu](mailto:expctrl@lits.upenn.edu)  
Phone: 215-573-8817

## APPENDIX F

Use the following letter as a Certification Statement for international shipments of non-regulated materials. Complete the text highlighted in yellow with the information appropriate for your shipment.

- LETTER HEAD -

DATE

Dear Sir/Madam,

I am writing to confirm that this package contains **XXX** *(simple description of the material, including quantity and volumes)* for medical research purposes only *(or for diagnostic testing)* and has no monetary value.

Recipient:  
**NAME**  
**ADDRESS**  
**TELEPHONE NUMBER**

The samples do not fall under IATA Dangerous Goods regulations.

*Enter needed "I certify" statements to declare this material as not regulated, non-hazardous, non-infectious. The following is an **example**:*

**I certify that the shipment contains no toxic or chemical substances, and is not subject to T S C A.**

**I certify that there is no animal originating material present. These samples are human material that was neither inoculated with nor exposed to, infectious agents of agricultural concern, including zoonotic agents. A materials transfer agreement has been agreed between sending and recipient parties. These samples are from patients with trauma who have been recruited into an observational research study and there is no reason to suspect they contain a biological infectious agent.**

The value for customs purposes: \$1.00 US Dollar.

I hereby declare the above information to be correct.

**YOUR NAME**  
**YOUR ADDRESS**  
**YOUR TELEPHONE NUMBER**  
**DATE**



NOTES: